

2012

L00139W

2/12



Clutches

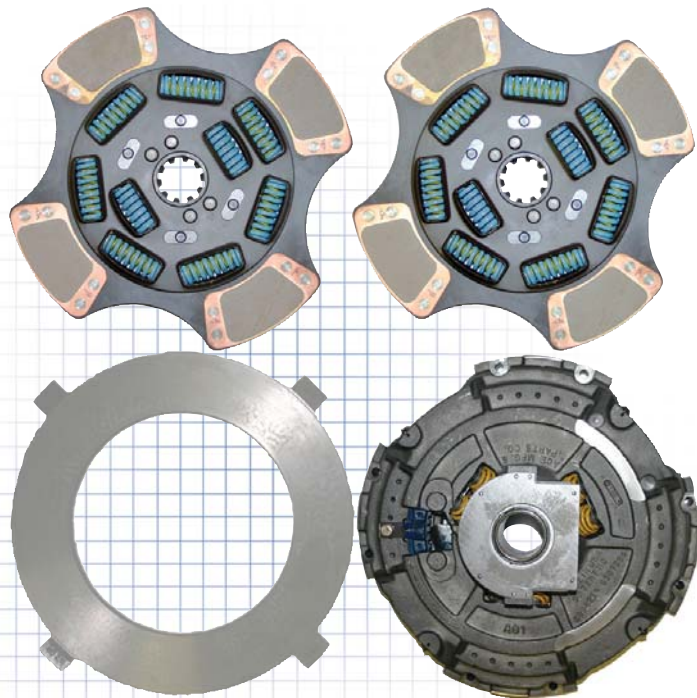

This page left blank intentionally.

08 – Clutches

Table of Contents	08-1
Part Number Index	08-5
General Information	
Foreword	08-7
General Information	08-8
Flywheel Counter Bore	08-9
Proper Flywheel Machining Dimensions	08-11
General Information	08-12
Application Guide	08-14
11" Borg & Beck Clutch Packs	
Push Type, Single Plate	08-24
11" GMC Clutch Packs	
Push Type, Single Plate	08-25
11" Long Clutch Packs	
Push Type, Single Plate	08-26
11" Luk Clutch Packs	
Push Type, Single Plate	08-27
12" Borg & Beck Clutch Packs	
Push Type, Single Plate	08-28
Push Type, Two Plate	08-29
12" Borg & Beck – Luk Clutch Packs	
Push Type, Single Plate	08-30
12" Lipe Clutch Packs	
Push Type, Single Plate	08-31
12" Long Clutch Packs	
Push Type, Single Plate	08-32
12" Rockford Clutch Packs	
Push Type, Single Plate	08-33
13" Borg & Beck Clutch Packs	
Push Type, Single Plate	08-34
13" Lipe Clutch Packs	
Push Type, Single Plate	
Flat Flywheel, 1.25"-10 Spline	08-35
Flat Flywheel, 1.38"-10 Spline	08-36
Flat Flywheel, 1.5"-10 Spline	08-37
Flat Flywheel, 1.75"-10 Spline	08-38
Push Type, Two Plate	
1.062 Recess Flywheel, 1.5"-10 Spline	08-39

08-CLUTCHES

Table of Contents

1.062 Recess Flywheel, 1.75"-10 Spline	08-40
1.478 Recess Flywheel, 1.5"-10 Spline	08-41
Pull Type, Two Plate	
Flat Flywheel, 1.75"-10 Spline	08-42
13" Long Clutch Packs	
Push Type, Single Plate	08-43
Push Type, Two Plate	08-44
13" Rockford Clutch Packs	
Push Type, Single Plate	08-45
14" Borg & Beck Clutch Packs	
Pull Type, Single Plate	08-46
14" COOL Standard Clutch Packs – Single Plate	08-47
14" COOL Standard Clutch Packs – Two Plate	08-48
14" COOL N EZ® Clutch Packs – Single Plate	08-49
14" COOL N EZ® Clutch Packs – Two Plate	08-50
14" EZ N LITE® Clutch Packs	08-51
14" Lipe Clutch Packs	
Pull Type, Single Plate	
Flat Flywheel, 1.75"-10/2.0"-10 Spline	08-52
Pull Type, Two Plate	
2.937 Recess Flywheel, 1.75"-10 Spline	08-53
2.937 Recess Flywheel, 2.0"-10 Spline	08-54
Flat Flywheel, 1.75"-10 Spline	08-55
Push Type, Single Plate	
1.187 Recess Flywheel, 1.5"-10 Spline	08-56
Flat Flywheel, 1.5"-10 Spline	08-57
Flat Flywheel, 1.75"-10 Spline	08-58
Push Type, Two Plate	
1.062 Recess Flywheel, 1.5"-10 Spline	08-59
1.093 Recess Flywheel, 1.75"-10 Spline	08-60
14" Long Clutch Packs	
Push Type, Single Plate	08-61
Push Type, Two Plate	08-62
14" Rockford Clutch Packs	
Push Type, Single Plate	08-63
14" Spicer Type Stamped Steel Clutch Packs	
Pull Type, Single Plate	
Flat Flywheel, 1.75"-10 Spline	08-64
Pull Type, Two Plate	
Flat Flywheel, 1.75"-10/2.0"-10 Spline	08-65
14" Spicer Type Clutch Packs – Standard	

Table of Contents

08-CLUTCHES

Pull Type, Two Plate	
2.937 Recess Flywheel, 1.75"-10 Spline	08-66
2.937 Recess Flywheel, 2.0"-10 Spline	08-67
14" Spicer Type Clutch Packs – Premium	
Pull Type, Two Plate	
2.937 Recess Flywheel, 1.75"-10 Spline	08-68
2.937 Recess Flywheel, 2.0"-10 Spline	08-69
14" Standard Clutch Pack – Spicer Type	08-70
15-1/2" AUTO N EZ® Self Adjusting Clutches	08-71
15-1/2" EZ N LITE® Clutch Packs	08-73
15-1/2" Spicer Type Clutch Packs – Standard	
Pull Type, Two Plate	
Flat Flywheel, 1.75"-10/2.0"-10 Spline	08-76
15-1/2" Spicer Type Clutch Packs – Premium	
Pull Type, Two Plate	
Flat Flywheel, 1.75"-10/2.0"-10 Spline	08-79
15-1/2" Standard Clutch Pack – Spicer Type	08-82
14" & 15-1/2" Meritor Type Clutch Packs	
Pull Type, Two Plate	
Flat Flywheel, 2.0"-10 Spline	08-83
Clutch Accessories	
Cover Assemblies	
for 11" Clutch	08-84
for 12" Clutch	08-85
for 13" Clutch	08-86
for 14" Clutch	08-87
Disc Assemblies	
for 11" Clutch	08-88
for 12" Clutch	08-89
for 13" Clutch	08-90
for 14" Clutch	08-91
for 15-1/2" Clutch	08-93
Intermediate Plates	
For Spicer Clutch Pack	08-95
Clutch Brake Spacer	08-96
Hinge Clutch Brake Kits	08-97
Drive Pins	08-98
Clutch Related Tools	08-99
Installation Kits	08-100
Maintenance	
Clutch Linkage	08-101

08-CLUTCHES

Table of Contents

Angle Spring 2-Plate Clutch	08-102
How to Improve Performance	08-104
Common Service Problems	08-105
Clutch Terms	08-107

Part Number Index

08-CLUTCHES

Part Number	Type	Page #	Part Number	Type	Page #	Part Number	Type	Page #	Part Number	Type	Page #
BK-312	O	08-97	N10768316CE	S	08-49	N128216C	S	08-93	RC141072X	S	08-87
BK-313	O	08-97	N1076835	S	08-47	N128229	S	08-91	RC141076X	S	08-87
BK312	S	08-97	N1076835CE	S	08-49	N128229C	S	08-91	RC141086X	S	08-87
BK313	S	08-97	N1076976CE	S	08-49	N128230	S	08-91	RC141098X	S	08-87
C026-0032	O	08-98	N10770116	S	08-48	N128230C	S	08-91	RC141101X	S	08-83
CA044X	S	08-87	N10770116CE	S	08-50	N128231	S	08-91	RC141113X	S	08-87
CP044	S	08-95	N10770316	S	08-48	N128232	S	08-91	RC141686X	S	08-87
MU018CX	S	08-79	N10770316CE	S	08-50	N128238	S	08-91	RC141707X	S	08-87
MU018EZCX	S	08-79	N1079151	S	08-47	N128239	S	08-91	RC141714X	S	08-87
MU018EZHTX	S	08-79	N1079151CE	S	08-49	N128257	S	08-93	RC141767X	S	08-87
MU018EZKX	S	08-79	N10792582	S	08-82	N128257C	S	08-93	RC141777X	S	08-87
MU018EZXX	S	08-79	N10792582C	S	08-82	N128258	S	08-93	RC141778X	S	08-87
MU018KX	S	08-79	N10793551	S	08-82	N128258C	S	08-93	RC141854X	S	08-87
MU018X	S	08-79	N10793551C	S	08-82	N128275	S	08-91	RC1477583X	S	08-46
MU390CX	S	08-69	N10803461	S	08-51	N128276	S	08-91	RC151406X	S	08-83
MU390DCX	S	08-69	N10803482	S	08-51	N128362	S	08-93	RC152705X	S	08-83
MU390DOX	S	08-69	N10803490	S	08-51	N128362C	S	08-93	RC152725X	S	08-83
MU390EZX	S	08-69	N10803553	S	08-51	N128363	S	08-93	RC1686607X	S	08-57
MU390EZDCX	S	08-69	N10803582	S	08-51	N128363C	S	08-93	RC1686640X	S	08-57
MU390EZDXX	S	08-69	N10803590	S	08-51	N128445	S	08-93	RC1707607X	S	08-53
MU390EZKX	S	08-69	N10805059	S	08-51	N128446	S	08-93	RC1714604X	S	08-55
MU390KX	S	08-69	N10805059C	S	08-51	N128462	S	08-93	RC1714618X	S	08-55
MU390ROX	S	08-69	N10806359	S	08-51	N128462C	S	08-93	RC1714704X	S	08-55
MU390SSCX	S	08-69	N10839174	S	08-73	N128521	S	08-91	RC1714718X	S	08-55
MU390SSOX	S	08-69	N10839174C	S	08-73	N128521C	S	08-91	RC1760646X	S	08-52
MU400DCX	S	08-68	N10839178	S	08-73	N128522	S	08-91	RC1760706X	S	08-54
MU400DOX	S	08-68	N10839181	S	08-73	N128522C	S	08-91	RC1767608X	S	08-54
MU400ROX	S	08-68	N10839181C	S	08-73	N128537	S	08-93	RC177607X	S	08-53
MU400SSCX	S	08-68	N10839182	S	08-73	N128537C	S	08-93	RC177608X	S	08-53
MU400SSOX	S	08-68	N10839193H	S	08-73	N128538	S	08-93	RC1779607X	S	08-54
MU476DCX	S	08-79	N10839193HC	S	08-73	N128538C	S	08-93	RC1778608X	S	08-54
MU476DOX	S	08-79	N10892520CTM	S	08-73	N128539	S	08-93	RC1778641X	S	08-54
MU476ROX	S	08-79	N10892520TM	S	08-73	N128539C	S	08-93	RC183145K	S	08-98
MU597CX	S	08-79	N10892525CTM	S	08-73	N128540	S	08-93	RC1854604X	S	08-52
MU597DCX	S	08-79	N10892525HCTM	S	08-73	N128540C	S	08-93	RC1854618X	S	08-52
MU597DOX	S	08-79	N10892525HTM	S	08-73	N128541	S	08-93	RC18574018X	S	08-24
MU597EZCX	S	08-79	N10892525TM	S	08-73	N128541C	S	08-93	RC18653904X	S	08-28
MU597EZDCX	S	08-79	N10892530CTM	S	08-73	N128574	S	08-91	RC18662824X	S	08-34
MU597EZDXX	S	08-79	N10892530TM	S	08-73	N128575	S	08-91	RC18662942X	S	08-34
MU597EZKX	S	08-79	N10892535CTM	S	08-73	N128578	S	08-91	RC18664182X	S	08-34
MU597KX	S	08-79	N10892535HCTM	S	08-73	N128579	S	08-91	RC19093904X	S	08-30
MU597ROX	S	08-79	N10892535HTM	S	08-73	N128604	S	08-93	RC19094195X	S	08-30
MU597SSCX	S	08-79	N10892535TM	S	08-73	N128604C	S	08-93	RC19191027X	S	08-34
MU597SSOX	S	08-79	N10892582	S	08-73	N2468K	S	08-100	RC1923LK	S	08-98
MU698CX	S	08-79	N10892582C	S	08-73	N3600K	S	08-100	RC1931134X	S	08-39
MU698EZCX	S	08-79	N10892582H	S	08-73	RC00331011X	S	08-27	RC1931144X	S	08-40
MU698EZHTX	S	08-79	N10892582HC	S	08-73	RC00491023X	S	08-27	RC1933114X	S	08-35
MU698EZKX	S	08-79	N10893551	S	08-73	RC018CX	S	08-76	RC1933117X	S	08-35
MU698EZXX	S	08-79	N10893551C	S	08-73	RC018DOX	S	08-76	RC1933134X	S	08-37
MU698X	S	08-79	N10893551H	S	08-73	RC018EZCX	S	08-76	RC1935136X	S	08-37
MU700CX	S	08-79	N10893551HC	S	08-73	RC018EZDOX	S	08-76	RC1937134X	S	08-39
MU700EZCX	S	08-79	N10893592HTM	S	08-73	RC018EZHTX	S	08-76	RC1938124X	S	08-36
MU700EZHTX	S	08-79	N10970061	S	08-71	RC018EZKX	S	08-76	RC1938127X	S	08-36
MU700EZKX	S	08-79	N10970078	S	08-71	RC018EZXX	S	08-76	RC1938134X	S	08-37
MU700EZXX	S	08-79	N10970092	S	08-71	RC018KX	S	08-76	RC1938137X	S	08-37
MU700X	S	08-79	N10970092HTM	S	08-71	RC018X	S	08-76	RC1940132X	S	08-41
N10703461	S	08-70	N10970120TM	S	08-71	RC02630568X	S	08-32	RC1940136X	S	08-41
N10703482	S	08-70	N10970125HTM	S	08-71	RC03860629KX	S	08-43	RC1941134X	S	08-41
N10703582	S	08-70	N10970125TM	S	08-71	RC04650872X	S	08-26	RC1989134X	S	08-39
N10705059	S	08-70	N10970130TM	S	08-71	RC05390094X	S	08-43	RC1989138X	S	08-39
N10705059C	S	08-70	N10970135HTM	S	08-71	RC05390629X	S	08-43	RC2070146X	S	08-42
N10706359	S	08-70	N10970135TM	S	08-71	RC0588756X	S	08-62	RC2070546X	S	08-42
N10709174	S	08-82	N10970174	S	08-71	RC06281251X	S	08-31	RC2077136X	S	08-37
N10709181	S	08-82	N10970181	S	08-71	RC06321001X	S	08-61	RC2461646X	S	08-38
N10709181C	S	08-82	N10970182	S	08-71	RC06670134X	S	08-31	RC2504LK	S	08-96
N10709182	S	08-82	N10970185	S	08-71	RC06671110X	S	08-31	RC2523KX	S	08-98
N10709193H	S	08-82	N10970193	S	08-71	RC10091023X	S	08-24	RC2540K	S	08-96
N10723710	S	08-48	N10970277	S	08-71	RC1014766X	S	08-44	RC3004K	S	08-99
N10723710CE	S	08-50	N127261	S	08-91	RC1047604X	S	08-57	RC3301931X	S	08-86
N10723722	S	08-48	N127262	S	08-91	RC1067645X	S	08-60	RC3301933X	S	08-86
N10723722CE	S	08-50	N127273	S	08-91	RC1067646X	S	08-60	RC3301935X	S	08-86
N10723724	S	08-48	N127274	S	08-91	RC1072604X	S	08-59	RC3301937X	S	08-86
N10723724CE	S	08-50	N127404	S	08-91	RC1072607X	S	08-59	RC3301938X	S	08-86
N10734222	S	08-48	N127405	S	08-91	RC1076604X	S	08-56	RC3301940X	S	08-86
N10734222CE	S	08-50	N127817	S	08-93	RC1086604X	S	08-57	RC3301941X	S	08-86
N10734224	S	08-48	N127818	S	08-93	RC1113604X	S	08-60	RC3301989X	S	08-86
N10734224CE	S	08-50	N128101	S	08-91	RC1113606X	S	08-60	RC3302077X	S	08-86
N1073424CE	S	08-50	N128102	S	08-91	RC1113646X	S	08-58	RC390CX	S	08-67
N10739174C	S	08-82	N128215	S	08-93	RC1113649X	S	08-60	RC390DCX	S	08-67
N10739178	S	08-82	N128215C	S	08-93	RC12663368X	S	08-29	RC390DOX	S	08-67
N10768316	S	08-47	N128216	S	08-93	RC141047X	S	08-87	RC390EZCX	S	08-67

Type "O" = OEM P/N, Type "S" = Service P/N

If OEM part # is not found on page listed, refer to the MCR for applicable cross reference.

08-CLUTCHES

Part Number Index

Part Number	Type	Page #	Part Number	Type	Page #	Part Number	Type	Page #	Part Number	Type	Page #
RC390EZDCX	S	08-67	RCD1001RX	S	08-91						
RC390EZDOX	S	08-67	RCD1011RX	S	08-88						
RC390EZKX	S	08-67	RCD1023RX	S	08-88						
RC390KX	S	08-67	RCD1110RX	S	08-89						
RC390ROX	S	08-67	RCD1251RX	S	08-89						
RC400DCX	S	08-66	RCD2824RX	S	08-90						
RC400DOX	S	08-66	RCD2942RX	S	08-90						
RC400EZDCX	S	08-66	RCD3348RX	S	08-88						
RC400EZDOX	S	08-66	RCD3735RX	S	08-88						
RC400ROX	S	08-66	RCD3904RX	S	08-89						
RC476DCX	S	08-76	RCD4018RX	S	08-88						
RC476DOX	S	08-76	RCD4148RX	S	08-88						
RC476ROX	S	08-76	RCD4182RX	S	08-90						
RC5362K	S	08-99	RCD4195RX	S	08-89						
RC5379K	S	08-99	RCD5121RX	S	08-89						
RC5380K	S	08-99	RCD5123RX	S	08-90						
RC5381K	S	08-99	RCD5139RX	S	08-91						
RC5409K	S	08-99	RCD5210RX	S	08-90						
RC5410K	S	08-99	TCT-014	O	08-99						
RC54245139X	S	08-63	TCT-017	O	08-99						
RC54295121X	S	08-33	TCT017	S	08-99						
RC54355123X	S	08-45	TCT5044	S	08-99						
RC54355210X	S	08-45									
RC54733735X	S	08-25									
RC55511011X	S	08-25									
RC55513348X	S	08-25									
RC55514148X	S	08-25									
RC597CX	S	08-76									
RC597DCX	S	08-76									
RC597DOX	S	08-76									
RC597EZCX	S	08-76									
RC597EZDCX	S	08-76									
RC597EZDOX	S	08-76									
RC597EZKX	S	08-76									
RC597ROX	S	08-76									
RC698CX	S	08-76									
RC698EZCX	S	08-76									
RC698EZHTX	S	08-76									
RC698EZKX	S	08-76									
RC698EZX	S	08-76									
RC698X	S	08-76									
RC700EZCX	S	08-76									
RC700EZHTX	S	08-76									
RC700EZKX	S	08-76									
RC700EZX	S	08-76									
RC700X	S	08-76									
RC7040999X	S	08-44									
RC747DCX	S	08-64									
RC747DOX	S	08-64									
RC892520EZX	S	08-76									
RC892525EZX	S	08-76									
RC892525HEZX	S	08-76									
RC892530EZX	S	08-76									
RC892535EZX	S	08-76									
RC892535HEZX	S	08-76									
RC893592HEZX	S	08-76									
RCA0033X	S	08-84									
RCA0049X	S	08-84									
RCA0263X	S	08-85									
RCA0465X	S	08-84									
RCA0539X	S	08-86									
RCA0628X	S	08-85									
RCA0632X	S	08-87									
RCA1009X	S	08-84									
RCA1014X	S	08-86									
RCA1857X	S	08-84									
RCA1865X	S	08-85									
RCA1866X	S	08-86									
RCA1882X	S	08-86									
RCA1909X	S	08-85									
RCA5424X	S	08-87									
RCA5429X	S	08-85									
RCA5435X	S	08-86									
RCA5473X	S	08-84									
RCA5505X	S	08-84									
RCA5551X	S	08-84									
RCD0094RX	S	08-90									
RCD0134RX	S	08-89									
RCD0568RX	S	08-89									
RCD0629RX	S	08-90									
RCD0872RX	S	08-88									

Type "O" = OEM P/N, Type "S" = Service P/N

If OEM part # is not found on page listed, refer to the MCR for applicable cross reference.

PURPOSE OF THIS SECTION

This section is designed as a reference for Haldex new and remanufactured air brake system components and accessories, sold under the Haldex and Midland product names. Products described include all pertinent information needed to replace an OEM installed component or to help design an original installation. If there is a service number for a given part, it is noted in the product number table.

DESIGN FLEXIBILITY

The products presented in this section are described by function and usage. Technical data and mounting configurations are also provided. Throughout this section, reference is made to numerous specific OEM applications. This section is not, however, intended to be a mutually exclusive listing of all part numbers and designs available. Should the need for a design not presented occur, contact your Haldex sales representative for additional information.

WARRANTY INFORMATION

Proper service and repair are important to the safe, reliable operation of any motor vehicle. To prevent personal injury and/or vehicle damage, careful and cautious service procedures recommended by the vehicle manufacturer should be followed by anyone servicing a motor vehicle. For details on warranty of Haldex air brake system components and accessories, refer to L20221 Aftermarket Warranty Policy. For warranty returns, use L90005 Warranty Adjustment Form. To obtain further information, visit the www.haldex.com website, select **North America/English** in drop down box then search for **Warranty**.

ORDERING PROCEDURE

Most customers can place electronic orders on the www.haldex.com website by obtaining a username and password or by using EDI. For additional information about electronic orders or to place an order by phone or fax, contact Customer Service in U.S. or Canada at numbers listed below:

U.S. Customer Service:

Phone: 800-643-2374
 Fax: 800-533-1941
 Mail: Haldex Brake Products Corporation
 Attn: Customer Service Department
 10930 N. Pomona Ave.
 Kansas City, MO 64153

Canada Customer Service:

Phone: 800-267-9247
 Fax: 519-621-3924
 Mail: Haldex Limited
 Canadian Distribution Centre
 Attn: Customer Service Department
 500 Pinebush Road, Unit 1
 Cambridge, Ontario N1T 0A5

IMPORTANT NOTICE

The data listed herein is correct to the best of Haldex's knowledge and belief, having been compiled from reliable and official sources of information. However, HALDEX CANNOT ASSUME ANY RESPONSIBILITY for possible error or misapplication of the product. Final determination of the suitability of the products for the use contemplated by the Buyer is the sole responsibility of the Buyer. Haldex shall have no responsibility in connection with this suitability. It is not our intention to imply that any of the components in this catalog in connection with an engine make or model are made by any engine manufacturer.

Copyright 2012
 Haldex Brake Products Corporation
 10930 N. Pomona Ave.
 Kansas City, MO 64153

All rights reserved.
 Materials may only be reproduced with written permission of Haldex.

IMPORTANT NOTICE

The data listed herein is correct to the best knowledge and belief of Haldex having been compiled from reliable and official sources of information. However, Haldex CANNOT ASSUME ANY RESPONSIBILITY for possible error or misapplication of the product. Final determination of the suitability of the products for the use contemplated by the Buyer is the sole responsibility of the Buyer. Haldex shall have no responsibility in connection with this suitability. It is not our intention to imply that any of the clutch assemblies listed in this catalog are produced by any specific engine manufacturer.

How to Use Catalog Format

This catalog is designed as a reference for technical data for Lipe clutch and isolator applications. The application section has been revised to simplify selection of the correct clutch pack for your application.

How to Select Your Service Application

1. Identify the vehicle make, model and year.
 - ◆ Identify the engine make
 - ◆ Determine the peak engine horsepower and torque rating
 - * Contact the engine manufacturer or a dealer for torque specifications if not available.
 - ◆ Identify Flywheel Type
 - a) Flat or Pot (if Pot, depth)
 - b) Center Counter Bore
 - c) Bolt Circle
2. Measure diameter of disc assembly
3. Visually determine if clutch release mechanism is Push Type or Pull Type
4. Measure the transmission input shaft size and number of teeth
5. Refer to any footnotes for additional information about your application.

FLYWHEEL COUNTER BORE INFORMATION

IMPORTANT: What is the flywheel counter bore on the vehicle?

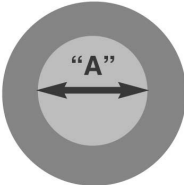
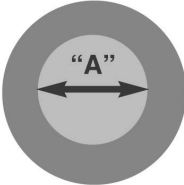
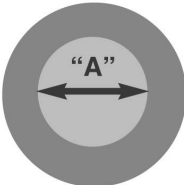
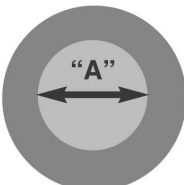
	4 Standard SAE Sizes ("A")	Typical Application Information
	7.09" – 7.25"	Standard discs with 7" spring retainers. *
	8.62" – 8.76"	10 spring discs and standard discs with 7" spring retainers will usually work
	9.28" – 9.38"	Disc spring retainer diameter usually needs to be minimum 8.5" to work
	10.1" – 10.14"	6, 7, 9 spring discs. 9" – 10" disc spring retainers needed

Flywheel Cross-Section

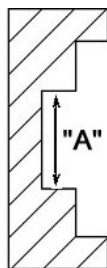

* Disc Cross-Section



FLYWHEEL COUNTER BORE INFORMATION

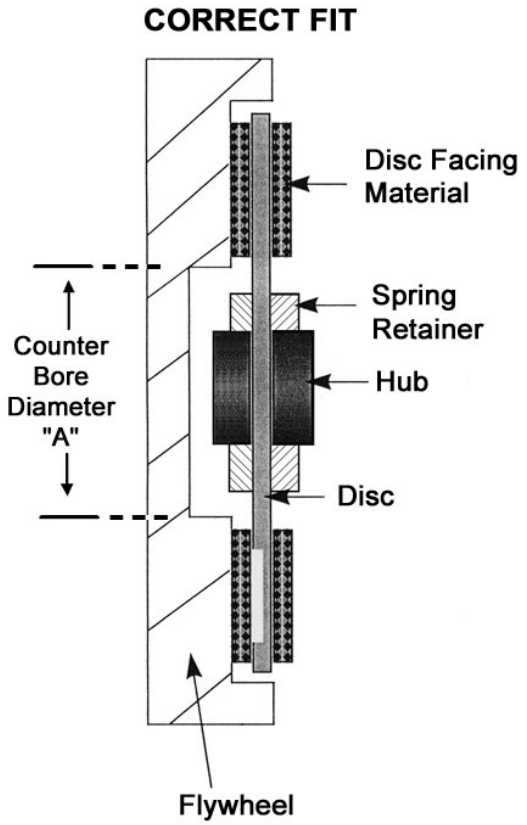

Same Disc Used on a Flywheel with a LARGER COUNTER BORE DIMENSION

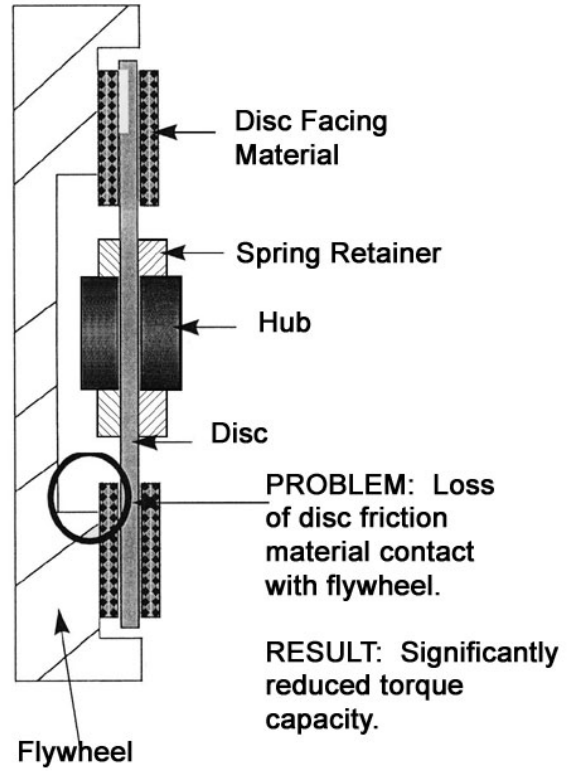

**Proper Flywheel Machining Dimensions
for Lipe Type 14" – 2 PT or Spicer Flywheels**

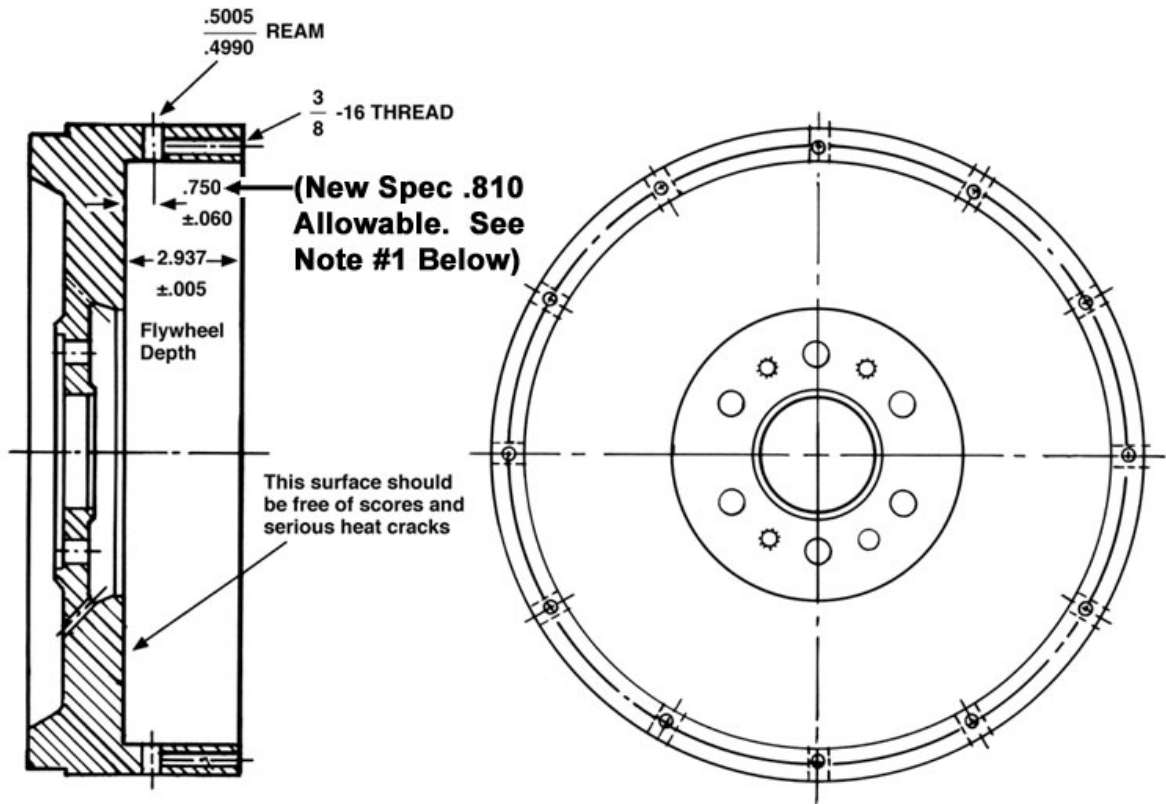

- 1) If the distance between the drive pin hole (centerline) and flywheel friction face exceeds .810 the flywheel needs to be replaced.
- 2) In applications that have experienced severe drive pin wear, it is recommended you use 12 drive pins in place of the standard 6.

EXPLANATION OF LIPE NUMBERING SYSTEM

LiPe Numbering System — Packs

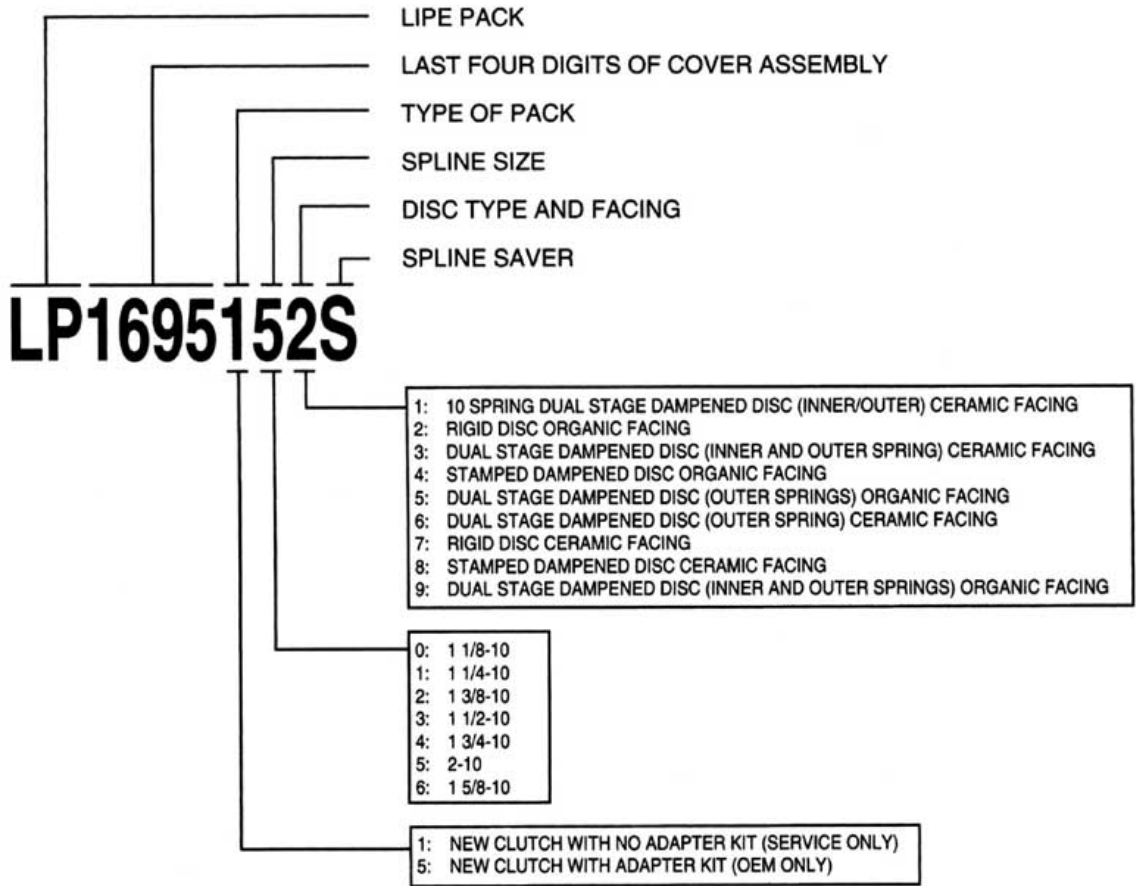

Lipe Numbering System — Covers

140-301-1076

DESIGNATES INCH SIZE OF COVER ASSEMBLY

130—13"	Cover Assembly
140—14"	Cover Assembly
150—15"	Cover Assembly
330—330 mm (13")	Cover Assembly

Designates Parts List or Bill of Material Number of Cover Assembly

DESIGNATES TYPE OF CLUTCH

NEW

031—Type DLB Single Plate (Push-Type)
032—Type DLB Two Plate (Push-Type)
051—Type DP Single Plate (Push-Type)
052—Type DP Two Plate (Push-Type)
061—Type DPB Single Plate (Push-Type)
062—Type DBP Two Plate (Push-Type)
081—Type DO Single Plate (oil) (Push-Type)
082—Type DO Two Plate (oil) (Push-Type)
301—Type DLB Single Plate (Push-Type)
302—Type DLB Two Plate (Push-Type)
501—Type DF Single Plate (Push-Type)
502—Type DF Two Plate (Push-Type)
701—Type LP Single Plate (Pull-Type)
702—Type LP Two Plate (Pull-Type)

"PUSH-TYPE" and "PULL-TYPE" COVER ASSEMBLIES
 In offering both "push-type" and "pull-type" assemblies, the Lipe line meets requirements of a wider range of applications. The basic difference in design concept for these two types of assemblies is simple:

In "push-type" cover applications, the release bearing is **pushed toward** the flywheel to effect disengagement.

In "pull-type" cover applications, the release bearing is **pulled away from** the flywheel to effect disengagement. As release is obtained in "pull-type" applications, the release bearing housing activates a brake on the transmission spline shaft to allow clash-free shifting.

Lipe Numbering System — Discs

140-009-1027

DESIGNATES INCH SIZE OF DISC ASSEMBLY

120—12"	Disc Assembly
130—13"	Disc Assembly
140—14"	Disc Assembly
150—15"	Disc Assembly

Designates Parts List or Bill of Material Number of Disc Assembly

DESIGNATES TYPE OF DISC ASSEMBLY

006—Rigid Type
008—Isolator Type
009—Spring Dampener Type
016—Rigid Cushion Type Disc
019—Spring Dampener Cushion Type

ENGINE HORSEPOWER/TORQUE RATINGS BY ENGINE MANUFACTURER

ENGINE	HP/@RPM		TORQUE/@RPM	
CAT3116	185	2600	520	1560
CAT3116	185	2200	520	1560
CAT3116	195	2200	521	1560
CAT3116	215	2200	605	1560
CAT3116	230	2200	660	1560
CAT3116	250	2200	660	1560
CAT3116	275	2200	750	1560
CAT3116 (GM-MD)	250	2600	650	1560
CAT3116 (GM-MD)	300	2600	732	1560
CAT3116 (GM 91-UP)	215	2600	605	1560
CAT3116 (GM 91-UP)	215	2600	550	1560
CAT3116 (GM-MD)	275	2450	735	1560
CAT3116 (HEU1)	170	2200	420	1560
CAT3116 (MD)	170	2600	420	1560
CAT3116 (MD)	200	2600	520	1560
CAT3116 G	185	2600	495	1560
CAT3126	175	2400	420	1440
CAT3126	190	2200	520	1440
CAT3126	210	2200	605	1440
CAT3126	210	2400	520	1440
CAT3126	230	2200	660	1440
CAT3126	250	2200	660	1440
CAT3126	250	2200	800	1440
CAT3126	275	2200	800	1440
CAT3126	275	2200	860	1440
CAT3126	300	2200	800	1440
CAT3126	300	2200	860	1440
CAT3176 ATMC	230	1800	975	1100
CAT3176 ATMC	250	2100	975	1300
CAT3176 ATMC	275	1800	1050	1100
CAT3176 ATMC	275	2100	1050	1200
CAT3176 ATMC	300	1800	1150	1100
CAT3176 ATMC	300	2100	1150	1300
CAT3176 ATMC	325	1900	1225	1200
CAT3176 ATMC	325	2100	1225	1300
CAT3176B	275	1800	1050	1100
CAT3176B	300	1800	1050	1100
CAT3176B	325	1800	1250	1200
CAT3176B	350	1800	1350	1200
CAT3176 ELEC	275	1800	1050	1100
CAT3176 ELEC	275	1800	975	1100
CAT3176 ELEC	300	1800	1050	1100
CAT3176 ELEC	300	1800	975	1100

ENGINE HORSEPOWER/TORQUE RATINGS BY ENGINE MANUFACTURER

ENGINE	HP/@RPM		TORQUE/@RPM	
CAT3208T (MD)	200	2000	620	1400
CAT3208T (MD)	200	2600	495	1560
CAT3208T (MD)	200	2600	520	1560
CAT3208T (MD)	250	2600	640	1400
CAT3306	245	2200	820	1300
CAT3306	245	2100	860	1350
CAT3306	250	1800	860	1350
CAT3306	260	1900	860	1350
CAT3306	270	2200	775	1400
CAT3306C	300	1900	1150	1200
CAT3406	250	1600	1000	1200
CAT3406	280	2100	1015	1200
CAT3406	290	1800	1000	1200
CAT3406	300	2100	1054	1200
CAT3406	310	1800	1090	1200
CAT3406	310	2100	1139	1100
CAT3406	310	1800	1140	1100
CAT3406	325	2100	1050	1200
CAT3406	330	1600	1320	1200
CAT3406	380	2100	1285	1200
CAT3406	400	1900	1450	1250
CAT3406	455	2100	1650	1200
CAT3406	455	1800	1460	1200
CAT3406	475	2100	1650	1750
CAT3406	500	2100	1450	1200
CAT3406	500	2100	1850	1200
CAT3406	550	2100	1850	1200
CAT3406	435	1800	1550	1650
CAT3406	500	2100	1450	1850
CAT3406 510	510	1600	1850	1200
CAT3406B	350	2100	1320	1200
CAT3406B	400	2100	1375	1260
CAT3406B	425	2100	1450	1200
CAT3406BEC	350	1800	1320	1200
CAT3406BEC	400	2100	1265	1300
CAT3406BEC	400	1800	1375	1260
CAT3406C	350	1800	1350	1200
CAT3406C	350	1800	1350	1200
CAT3406C	425	1800	1550	1200
CAT3406C	425	1900	1650	1200
CAT3406E	310	1800	1150	1200
CAT3406E	310	1800	1250	1200
CAT3406E	330	1800	1350	1200

ENGINE HORSEPOWER/TORQUE RATINGS BY ENGINE MANUFACTURER

ENGINE	HP/@RPM		TORQUE/@RPM	
CAT 3406E	375	1800	1450	1200
CAT 3406E	410	1800	1450	1200
CAT 3406E	435	1800	1550	1200
CAT 3406E	435	2100	1650	1200
CAT 3406E	435	2100	1550	1200
CAT 3406E	475	2100	1650	1200
CAT 3406E	475	1800	1650	1200
CAT 3406E	475	1800	1750	1200
CAT 3406E	475	2100	1750	1200
CAT 3406E	550	1800	1850	1200
CAT 3406E(94)	355	1800	1350	1200
CAT 3406E(94)	355	1800	1450	1200
CAT 3406E(94)	375	1800	1550	1200
CAT 3406E(94)	410	1800	1550	1200
CAT 3406E(94)	435	1800	1650	1200
CAT 3406E(94)	475	1800	1750	1200
CAT 3406E(94)	500	1800	1850	1200
CAT 3406E MULTI TQ	310	1800	1150/1350	1200
CAT 3406E MULTI TQ	355	1800	1350/1450	1200
CAT 3406E MULTI TQ	375	1800	1450/1550	1200
CAT 3406E MULTI TQ	375/435	1800	1450/1550	1200
CAT 3408	420	1900	1460	1200
CAT 3408	450	2100	1350	1500
CAT 3408	450	2100	1460	1200
CAT 6CTA-250	250	2200	720	1300
CAT C-10	280	1800	1050	1100
CAT C-10	280	2100	975	1100
CAT C-10	305	1800	1150	1100
CAT C-10	305	2100	1150	1100
CAT C-10	325	2100	1250	1200
CAT C-10	335	1800	1250	1200
CAT C-10	335	1800	1350	1200
CAT C-10	350	1800	1350	1200
CAT C-10	370	1800	1350	1200
CAT C-10 MULTI	335/370	1800	1250/1350	1200
CAT C-12	355	1800	1350	1200
CAT C-12	360	2100	1350	1200
CAT C-12	380	1800	1450	1200
CAT C-12	390	2100	1450	1200
CAT C-12	410	1800	1450	1200
CAT C-12	410	1800	1550	1200
CAT C-12	410	2100	1550	1200
CAT C-12 MULTI TQ	355/410	1800	1350/1450	1200

ENGINE HORSEPOWER/TORQUE RATINGS BY ENGINE MANUFACTURER

ENGINE	HP/@RPM		TORQUE/@RPM	
CAT C-12 MULTI TQ	355/410	1800	1350/1450	1200
CAT C-12 MULTI TQ	380/410	1800	1450/1550	1200
CAT C-12 RCV/BUS	425	2100	1450	1200
CAT G3306 CNG/LNG	235	2100	800	1200
CAT G3306 LPG (HD5)	250	2100	820	1200
CUM 444	444	2100	1400	1500
CUM 4BT3.9	105	2500	260	1700
CUM 4BTA3.9	120	2500	304	1700
CUM 6BT55.9	160	2500	400	1700
CUM 6BTA5.9	190	2500	475	1600
CUM 6BTA5.9	210	2500	520	1600
CUM 6BTA5.9	230	2500	605	1600
CUM 6CT8.3	210	2200	605	1500
CUM 6CTA8.3	240	2200	645	1500
CUM 6CTA8.3	250	2200	728	1500
CUM FLEET 270	270	1600	1020	1100
CUM FLEET 285	285	1600	1150	1100
CUM FLT 300	300	1700	1150	1100
CUM FORM-300	300	1800	1000	1300
CUM FORM-L10-240	240	1400	858	1300
CUM FORM-VT-350	300	2100	860	1400
CUM FORM 240	240	1800	870	1300
CUM FORM 270	270	1800	1000	1300
CUM FORM 315	315	1800	1150	1300
CUM FORM 350(90)	350	1800	1175	1300
CUM FORM 350(90)	350	1800	1200	1300
CUM FORM 365(90)	365	1800	1325	1300
CUM FORM 400	400	1800	1250	1300
CUM FORM 450	450	1900	1420	1300
CUM KT 450	450	2100	1350	1500
CUM KT 525	525	2100	1650	1300
CUM KTA 600	600	2100	1650	1600
CUM L-10	260	1800	975	1200
CUM L-10	270	1900	858	1300
CUM L-10	270	2100	858	1400
CUM L-10	280	1800	1050	1200
CUM L-10	300	2100	950	1300
CUM L-10 240	240	1900	870	1300
CUM L-10 240/250PT	240-2100	250-2200	900	1300
CUM L-10 285PT	285	2200	1020	1300
CUM L-10 310	310	1800	1150	1200
CUM L-10 330E	330	1800	1250	1200

ENGINE HORSEPOWER/TORQUE RATINGS BY ENGINE MANUFACTURER

ENGINE	HP/@RPM		TORQUE/@RPM	
CUM L-10 FORM	300	1900	950	1300
CUM L-10 FORM 240	240	1900	860	1300
CUM L-10 STC 12 CGC	280	1600	1050	1200
CUM L-10 STC 12 CGD	280	1700	1050	1200
CUM L-10 STC 12 CGH	300	1700	1150	1200
CUM L-10 STC 12CGA	260	1600	975	1200
CUM L-10 STC 12CGB	260	1700	975	1200
CUM L-10 STC 12CGG	310	1600	1150	1200
CUM M11	400	1800	1450	1200
CUM M11 280E	280	1800	1050	1200
CUM M11 280E	280	2000	1050	1200
CUM M11 280E CELECT	280	2000	1050	1200
CUM M11 280E CELECT	280	1800	1050	1200
CUM M11 31 OE	310	2000	1150	1200
CUM M11 31 OE	310	1800	1150	1200
CUM M11 330E	330	2000	1350	1200
CUM M11 330E	330	800	1350	1200
CUM M11 350E	350	1800	1350	1200
CUM M11 350E	350-390	2000	1350	1200
CUM M11 370	370	1800	1350	1200
CUM M11 370	370	2000	1350	1200
CUM M11 ESP1	280-330	1800	1050-1250	1200
CUM M11 ESP11	310-370	1800	1150	1350
CUM N14 12 CEC	370	1600	1400	1200
CUM N14 12 CED	370	1600	1400	1200
CUM N14 310	310	1800	1150	1350
CUM N14 330E	330	2100	1350	1200
CUM N14 330E	330	600	1350	1200
CUM N14 350E	350	2100	1400	1200
CUM N14 350E	350	1800	1400	1200
CUM N14 370E	370	2100	1450	1200
CUM N14 370E	370	1800	1450	1200
CUM N14 410E	410	2100	1450	1200
CUM N14 410E	410	1800	1450	1200
CUM N14 435E	435	2100	1650	1200
CUM N14 435E	435	2100	1550	1200
CUM N14 435E	435	1800	1450	1200
CUM N14 469E	460	2100	1650	1200
CUM N14 500	500	1800	1750	1200
CUM N14 500E	500	2100	1750	1200
CUM N14 500E	500	2100	1650	1200
CUM N14 500E	500	1750	1650	1600
CUM N14 525	525	1800	1850	1200

ENGINE HORSEPOWER/TORQUE RATINGS BY ENGINE MANUFACTURER

ENGINE	HP/@RPM		TORQUE/@RPM	
CUM N14 CELECT 12 CDB	370	1600	1400	1100
CUM N14 CELECT 12 CDC	430	1700	1450	1100
CUM N14 CELECT 12 CDI	350	1600	1400	1100
CUM N14 CELECT 12 CDI	350	1600	1350	1100
CUM N14 CELECT 12 CDJ	460	1700	1550	1100
CUM N14 CELECT 12 CDK	310	1600	1250	1300
CUM N14 CELECT 12 CDR	310	1699	1450	1200
CUM N14 CELECT 12 CDS	330	1600	1350	1100
CUM N14 CELECT 12 CDS	370	1600	1550	1200
CUM N14 CELECT 12 CEN	410	1600	1450	1200
CUM N14 CELECT 12 CEP	430	1700	1550	1300
CUM N14 EAP1	310-390	1800	1250	1450
CUM N14 ESP11	350	1800	1350	1500
CUM N14 ESP3	400-460	1800	1450	1650
CUM N14 STC 12 CEE	410	1600	1450	1200
CUM N14 STC 12 CEG	410	1600	1450	1200
CUM N14 STC 12 CEH	310	1600	1250	1100
CUM N14 STC 12 CEJ	350	1600	1400	1100
CUM N14 STC 12 CEK	350	1600	1350	1100
CUM NHTC-220	220	2100	644	1500
CUM NTC-FORM 400	400	1800	1325	1300
CUM NTC 315	315	1800	1150	1300
CUM NTC 350	350	2100	1120	1300
CUM NTC 365	365	1800	1320	1300
CUM NTC 400	400	2100	1250	1300
CUM NTC 475	475	2100	1430	1400
CUM NTC 300	300	2100	1000	1300
CUM NTC 350(90)	350	2100	1200	1300
CUM NTC 444NT	444	2100	1400	1500
CUM PT-240	240	2100	900	1300
CUM PT 270	270	1800	1000	1300
CUM STC 12 CEA	330	1600	1350	1100
CUM STC 12 CEB	330	1600	1350	1100
CUM TWIN TURBO	475	2100	1430	1400
CUM V-903C	295	2600	1000	1800
DD 11.1L	250	1800	970	1200
DD 11.1L	300	1800	1150	1200
DD 11.1L	330	1800	1150	1200
DD 11.1L	330	1800	1250	1200
DD 11.1L	330	1800	1250	1200
DD 11.1L	350	1800	1250	1200
DD 11.1L	350	1800	1250	1200

ENGINE HORSEPOWER/TORQUE RATINGS BY ENGINE MANUFACTURER

ENGINE	HP/@RPM	TORQUE/@RPM
DD 11.1L	350 1800	1350 1200
DD 11.1L	365 1800	1350 1200
DD 11.1L	220-365 1800	1350 1200
DD 11.1L	300-330 1800	1150 1200
DD 11.1L	330-350 1800	1350 1200
DD 12.7L	350 2100	1400 1200
DD 12.7L	370 1800	1450 1200
DD 12.7L	370 2100	1450 1200
DD 12.7L	400 1800	1450 1200
DD 12.7L	400 2100	1450 1200
DD 12.7L	425 2100	1400 1200
DD 12.7L	430 1800	1450 1200
DD 12.7L	430 1800	1450 1200
DD 12.7L	430 2100	1450 1200
DD 12.7L	430 1800	1550 1200
DD 12.7L	430 2100	1550 1200
DD 12.7L	470 2100	1450 1200
DD 12.7L	470 1800	1550 1200
DD 12.7L	470 2100	1550 1200
DD 12.7L	500 1800	1550 1200
DD 12.7L	500 2100	1550 1200
DD 12.7L	370-400 1800	1450 1200
DD 12.7L	370-430 1800	1450 1200
DD 12.7L	430-470 1800	1550 1200
DD 6-71	230 2100	611 1600
DD 6-71T	275 2100	853 1200
DD 6-71T	300 2100	830 1400
DD 6-71TAC	270 2100	786 1200
DD 6V92TA	330 2100	963 1200
DD 6V92TA	350 2100	1020 1200
DD 6V92TA	445 2100	1250 1300
DD 8V71	304 2100	818 1400
DD 8V92TAC	440 2100	1250 1300
DD 8V92TA	400 1800	1250 1200
DD 8V92TA	475 2100	1330 1300
DD SERIES 50 8.5L-1L-4	250 2100	780 1200
DD SERIES 50 8.5L-1L-4	275 2100	890 1200
DD SERIES 50 8.5L-1L-4	300 1800/2100	1000 1200
DD SERIES 50 8.5L-1L-4L	315 1950/2100	1150 1200
DD SERIES 55 12L-1L-6	300 1800	1150 1100
DD SERIES 55 12L-1L-6	330 1800/2000	1250 1100
DD SERIES 55 12L-1L-6	350 1800/2000	1250/1350 1100

ENGINE HORSEPOWER/TORQUE RATINGS BY ENGINE MANUFACTURER

ENGINE	HP/@RPM	TORQUE/@RPM
DD SERIES 55 12L-1L-6	350 1800/2200	1350 1100
DD SERIES 55 12L-1L-6	365 1800/2000	1450 1100
DD SERIES 55 12L-1L-6	330/350 1800	1250 1100
DD SERIES 55 12L-1L-6	330/350 1800	1350 1100
DD SERIES 55 12L-1L-6	365/400 1800	1450 1100
DD SERIES 60 11.1L-1L-6	300 1800	1150 1200
DD SERIES 60 11.1L-1L-6	330 1800	1150 1200
DD SERIES 60 11.1L-1L-6	330 1800	1150 1200
DD SERIES 60 11.1L-1L-6	350 1800	1250 1200
DD SERIES 60 11.1L-1L-6	350 2100	1250 1200
DD SERIES 60 11.1L-1L-6	350 2100	1250 1200
DD SERIES 60 11.1L-1L-6	365 1800	1350 1200
DD SERIES 60 11.1L-1L-6	300/330 1800	1150 1200
DD SERIES 60 11.1L-1L-6	330/350 1800	1250 1200
DD SERIES 60 11.1L-1L-6	330/365 1800	1350 1200
DD SERIES 60 12.7-1L-6	400 1800	1450 1200
DD SERIES 60 12.7-1L-6	400 2100	1450 1200
DD SERIES 60 12.7-1L-6	370/400 1800	1450 1200
DD SERIES 60 12.7L-1L-6	370 1800	1450 1200
DD SERIES 60 12.7L-1L-6	370 2100	1450 1200
DD SERIES 60 12.7L-1L-6	430 1800	1450 1200
DD SERIES 60 12.7L-1L-6	430 2100	1450 1200
DD SERIES 60 12.7L-1L-6	470 1800	1550 1200
DD SERIES 60 12.7L-1L-6	470 2100	1450/1550 1200
DD SERIES 60 12.7L-1L-6	500 1800	1550 1200
DD SERIES 60 12.7L-1L-6	500 2100	1450/1550 1200
DD SERIES 60 12.7L-1L-6	370/430 1800	1450 1200
DD SERIES 60 12.7L-1L-6	370/430 2100	1450 1200
DD SERIES 60 12.7L-1L-6	430/470 1800	1550 1200
DD SERIES 60 12.7L-1L-6	430/470 2100	1550 1200
DD SERIES 92 12.1L-V-8	400 2100	1330 1200
DD SERIES 92 12.1L-V-8	450 2100	1425 1200
DD SERIES 92 12.1L-V-8	500 2100	1470 1200
DD SERIES 92 9.05L-V-6	300 2100	975 1200
DD SERIES 92 9.05L-V-6	350 2100	1020 1200
FORD FD-1060	160 2500	400 1600
FORD FD-1060	175 2500	420 1600
FORD FD-1060	190 2500	475 1600
FORD FD-1060	210 2500	485 1600
FORD FD-1060	210 2300	520 1600
FORD FD-1060	230 2300	605 1600
FORD FD-1460	210 2200	605 1300
FORD FD-1460	225 2200	660 1300

ENGINE HORSEPOWER/TORQUE RATINGS BY ENGINE MANUFACTURER

ENGINE	HP/@RPM		TORQUE/@RPM	
FORD FD-1460	250	2200	660	1300
FORD FD-1460	250	2000	800	1300
FORD FD-1460	275	2000	800	1300
FORD FD-1460	275	1800	860	1300
FORD 7.3L HI-ALT	165	3000	325	1600
FORD 7.3L NATASP	185	3000	360	1400
FORD 7.3L TURBO	190	3000	395	1400
GM 6.5L NATASP	155	3600	275	1700
GM 6.5L NATASP	160	3400	290	1700
GM 6.5L TURBO	180	3400	360	1700
GM 6.5L TURBO	190	3400	385	1700
INTL 530	250	2200	800	1300
INTL 530	275	2000	950	1300
INTL 530	275	2200	860	1300
INTL 530	300	2200	950	1300
INTL 530	300	2000	1050	1300
INTL DT-408	190	2600	485	1800
INTL DT-408	210	2600	520	1800
INTL DT-408	230	2600	605	1800
INTL DT-408	175	2600	430	1800
INTL DT-466	195	2400	520	1600
INTL DT-466	210	2400	605	1600
INTL DT-466	230	2400	660	1600
INTL DT-466	250	2400	660	1600
INTL DT-466	275	2400	800	1600
INTL T444E	160	2600	400	1500
INTL T444E	175	2600	430	1500
INTL T444E	190	2600	485	1500
MACK E3-190 (MECH) CAT	190	2500	475	1300
MACK E3-220 (MECH)	220	2350	627	1400
MACK E6-250	250	2100	750	1500
MACK E6-275	275	2100	1020	1200
MACK E6-300	300	1700	1112	1200
MACK E6-350	350	1800	1277	1250
MACK EM6-250	250	2100	940	1260
MACK EM6-250L	250	1750	1190	1020
MACK EM6-275	275	2100	1038	1260
MACK EM6-275L	275	1750	1305	1020
MACK EM6-300L	300	1750	1425	1020
MACK E7-250 (MECH)	250	1950	975	1200

ENGINE HORSEPOWER/TORQUE RATINGS BY ENGINE MANUFACTURER

ENGINE	HP/@RPM		TORQUE/@RPM	
MACK E7-300 (MECH)	300	1950	1083	1200
MACK E7-300 (V-MAC)	300	1700	1160	1200
MACK E7-325 VMAC	325	1800	1260	1250
MACK E7-350	350	1800	1277	1250
MACK E7-350 VMAC	350	1800	1250	1250
MACK E7-375 VMAC	375	1800	1460	1250
MACK E7-400	400	1800	1460	1250
MACK E7-427	427	1800	1560	1250
MACK E7-454	454	1800	1560	1250
MACK EM7-250 (MECH)	250	1750	1190	1020
MACK EM7-250L	250	1750	1190	1020
MACK EM7-275 (MECH)	275	1750	1305	1250
MACK EM7-275 (V-MAC)	275	1750	1305	1250
MACK EM7-300 (MECH)	300	1750	1425	1020
MACK EM7-300VMAC	300	1750	1425	1020
MACK E9	550	2100	1660	1300
MACK E9 450	450	1900	1495	1300
MACK E9 500	500	1900	1660	1300
VOLVO 260E/300AE	260	2100	800	1080
VOLVO 280G/330BE	280	1700	925	1200
VOLVO 300-A360CE	300	2100	925	1200
VOLVO 300CC/410DE	300	2100	955	1200
VOLVO 310B	310	1900	985	1200

Push Type, Single Plate

(1)

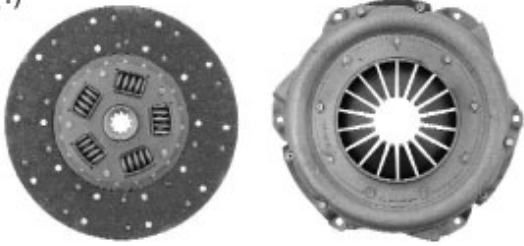

Notes:

- 1) Discs are remanufactured.
- 2) Discs purchased separately are outright. No core charge/return applicable.

(2)

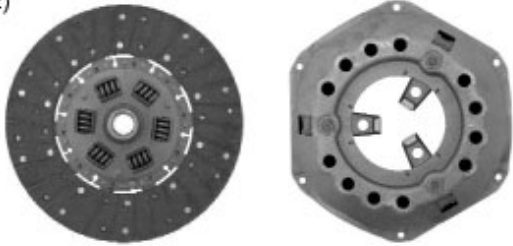

SKU#	Product Description	Cover Assembly	Disc Assembly	Disc Type	Spline Size	Approx. Weight	Application	Pic. #	Core Group
RC10091023X	Remanufactured Single Plate, (Cone Diaphragm) Push Type Clutch Pack	RCA1009X	RCD1023RX	Damp Organic	1-1/16" - 10T	30 lbs.	Ford	1	CA1101
RC18574018X	Remanufactured Single Plate, Push Type Clutch Pack	RCA1857X	RCD4018RX	Damp Organic	1" - 23T	30 lbs.	Dodge	2	CA1101

Push Type, Single Plate

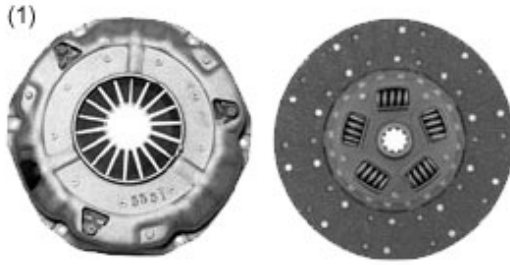

Features:

- Diaphragm Style Cover

Specifications:

Approximate Weight 28 lbs.

Notes:

- 1) Discs are remanufactured.

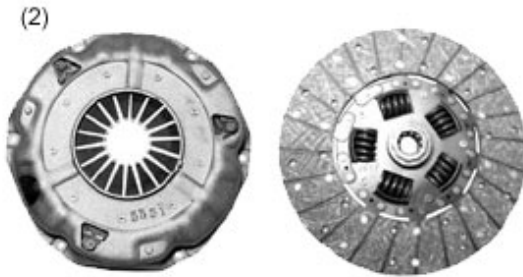

SKU#	Product Description	Cover Assembly	Disc Assembly	Disc Type	Spline Size	Diaphragm	Application	Pic. #	Core Group
RC54733735X	Reman. Single Plate, Push Type Clutch Pack	RCA5473X	RCD3735RX	Damp Organic	1-1/8" - 10T	Flat	Chevrolet - GMC	1	CA1101
RC55511011X	Remanufactured Single Plate, Push Type Clutch Pack	RCA5505X	RCD1011RX	Damp Organic	1-1/16" - 10T	Cone	Special	2	CA1101
RC55513348X	Remanufactured Single Plate, Push Type Clutch Pack	RCA5551X	RCD3348RX	Damp Organic	1-1/8" - 10T	Crown	Chevrolet - GMC	2	CA1101
RC55514148X	Remanufactured Single Plate, Push Type Clutch Pack	RCA5551X	RCD4148RX	Damp Organic	1-1/8" - 26T	Crown	Chevrolet - GMC	2	CA1101

Push Type, Single Plate

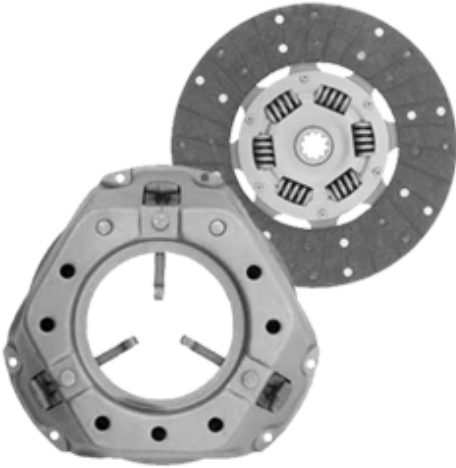

Notes:

- 1) Discs are remanufactured.
- 2) Discs purchased separately are outright. No core charge/return applicable.

SKU#	Product Description	Cover Assembly	Disc Assembly	Disc Type	Spline Size	Approx. Weight	Application	Core Group
RC04650872X	Remanufactured Single Plate, Push Type Clutch Pack	RCA0465X	RCD0872RX	Damp Organic	1-1/16" - 10T	23 lbs.	Ford	CA1101

Push Type, Single Plate

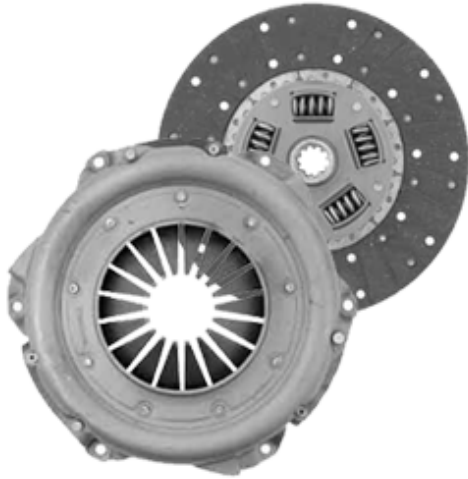

Notes:

- 1) Discs are remanufactured.

SKU#	Product Description	Cover Assembly	Disc Assembly	Disc Type	Spline Size	Approx. Weight	Application	Core Group
RC00331011X	Remanufactured Single Plate, Push Type Clutch Pack	RCA0033X	RCD1011RX	Damp Organic	1-1/16" - 10T	30 lbs.	Ford	CA1101
RC00491023X	Remanufactured Single Plate, Push Type Clutch Pack	RCA0049X	RCD1023RX	Damp Organic	1-1/16" - 10T	30 lbs.	Ford	CA1101

Push Type, Single Plate



Notes:

- 1) Discs are remanufactured.
- 2) Discs purchased separately are outright. No core charge/return applicable.

SKU#	Product Description	Cover Assembly	Disc Assembly	Disc Type	Spline Size	Approx. Weight	Application	Core Group
RC18653904X	Remanufactured Single Plate, Push Type Clutch Pack	RCA1865X	RCD3904RX	Damp Organic	1-1/8" – 10T	28 lbs.	Chevrolet-GMC (Gas)	CA1201

Push Type, Two Plate

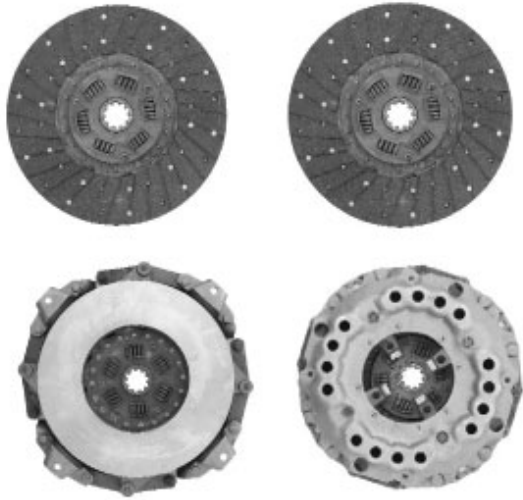

Notes:

- 1) Discs are remanufactured.

SKU#	Product Description	Disc Type	Spline Size	Approx. Weight	Application	Core Group
RC12663368X	Remanufactured Two Plate, Push Type Clutch Pack	Damp Organic (2)	1-1/2" - 10T	59 lbs.	Chevrolet-GMC	CA1201

Push Type, Single Plate

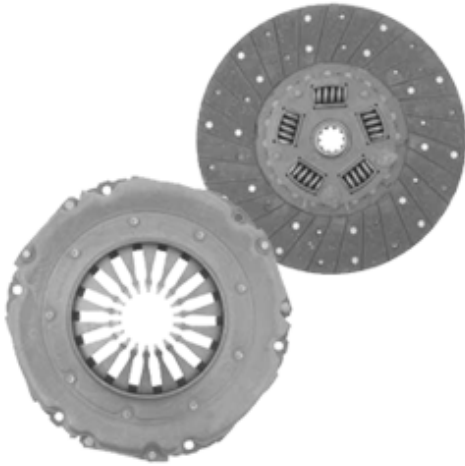

Notes:

- 1) Discs are remanufactured.
- 2) Discs purchased separately are outright. No core charge/return applicable.

SKU#	Product Description	Cover Assembly	Disc Assembly	Disc Type	Spline Size	Approx. Weight	Application	Core Group
RC19093904X	Remanufactured Single Plate, (Bent Diaphragm) Push Type Clutch Pack	RCA1909X	RCD3904RX	Damp Organic	1-1/8" – 10T	28 lbs.	Chevrolet-GMC (Gas)	CA1201
RC19094195X	Remanufactured Single Plate, (Bent Diaphragm) Push Type Clutch Pack	RCA1909X	RCD4195RX	Damp Organic	1-1/8" – 10T	28 lbs.	Chevrolet-GMC (Diesel)	CA1201

Push Type, Single Plate



Notes:

- 1) Discs are remanufactured.
- 2) Discs purchased separately are outright. No core charge/return applicable.

SKU#	Product Description	Cover Assembly	Disc Assembly	Disc Type	Spline Size	Approx. Weight	Application	Core Group
RC06281251X	Remanufactured Single Plate, Push Type Clutch Pack	RCA0628X	RCD1251RX	Damp Ceramic	1-1/2" – 10S	42 lbs.	Timberjack	LP1201
RC06670134X	Remanufactured Single Plate, Push Type Clutch Pack	RCA0667X	RCD0134RX	Damp Organic	1-1/8" – 10T	34 lbs.	Chevrolet-GMC	LP1201
RC06671110X	Remanufactured Single Plate, Push Type Clutch Pack	RCA0667X	RCD1110RX	Damp Organic	1-3/8" – 10T	25 lbs.	Ford	LP1201

Push Type, Single Plate

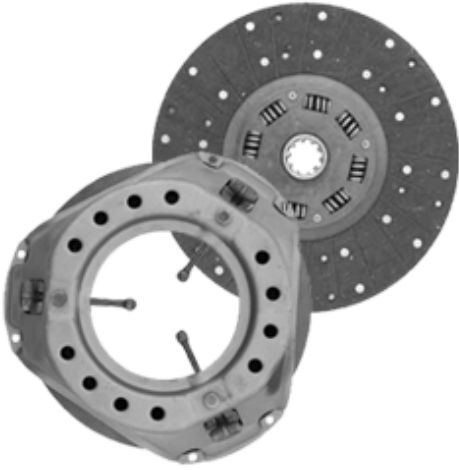

Notes:

- 1) Discs are remanufactured.
- 2) Discs purchased separately are outright. No core charge/return applicable.

SKU#	Product Description	Cover Assembly	Disc Assembly	Disc Type	Spline Size	Approx. Weight	Application	Core Group
RC02630568X	Remanufactured Single Plate, Push Type Clutch Pack	RCA0263X	RCD0568RX	Damp Organic	1-3/8" - 10T	30 lbs.	Ford	CA1201

Push Type, Single Plate

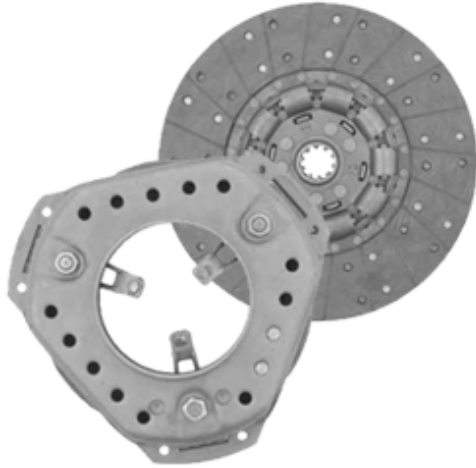

Notes:

- 1) Discs are remanufactured.
- 2) Discs purchased separately are outright. No core charge/return applicable.

SKU#	Product Description	Cover Assembly	Disc Assembly	Disc Type	Spline Size	Approx. Weight	Application	Core Group
RC54295121X	Remanufactured Single Plate, Push Type Clutch Pack	RCA5429X	RCD5121RX	Damp Organic	1-1/4" - 10T	34 lbs.	International	CA1201

Push Type, Single Plate

(1)



Notes:

- 1) Discs are remanufactured.
- 2) Discs purchased separately are outright. No core charge/return applicable.

(2)

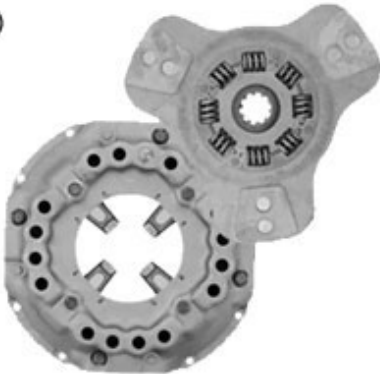

(3) Diaphragm Style Cover
(not illustrated)

SKU#	Product Description	Cover Assembly	Disc Assembly	Disc Type	Spline Size	Approx. Weight	Application	Pic. #	Core Group
RC18662824X	Remanufactured Single Plate, Push Type Clutch Pack	RCA1866X	RCD2824RX	Damp Organic	1-1/2" - 10T	35 lbs.	Chevrolet-GMC	1	CA1301
RC18662942X	Remanufactured Single Plate, Push Type Clutch Pack	RCA1866X	RCD2942RX	Damp Organic	1-3/8" - 10T	35 lbs.	Dodge	1	CA1301
RC18664182X	Remanufactured Single Plate, Push Type Clutch Pack	RCA1882X	RCD4182RX	Damp Ceramic	1-1/2" - 10T	33 lbs.	Chevrolet-GMC	2	CA1301
RC19191027X	Remanufactured Single Plate, Push Type Clutch Pack - Diaphragm	RCA1919X	N/A	Damp Ceramic	1-1/2" - 10T	45 lbs.	Chevrolet-GMC	3	CA1301

Push Type, Single Plate

Flat Flywheel, 1.25"-10 Spline

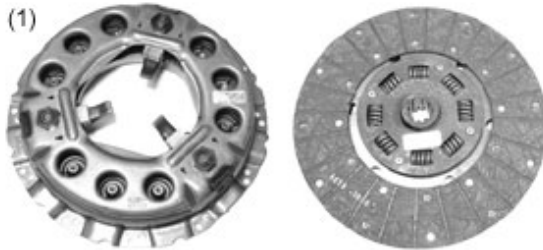

Features:

- Remanufactured Lipe Clutch Packs contain a remanufactured cover assembly and new disc assembly.
- Replacement disc assemblies available in new only.

Specifications:

Approximate Weight 35 lbs.



SKU#	Product Description	Cover Assembly	Disc Assembly	Disc Type	Max. Torque	Bolt Circle	Application	Picture Number	Core Group
RC1933114X	Reman. Push Type, Single Plate, Flat Flywheel, 1.25"-10 Spline	RC3301933X	1300091802	Damp Organic	350	14.125 14.625	Perkins Navistar	1	LP3301
RC1933117X	Reman. Push Type, Single Plate, Flat Flywheel, 1.25"-10 Spline	RC3301933X	1300091902	Damp Ceramic	600	14.125 14.625	Navistar	2	LP3301

Push Type, Single Plate

Flat Flywheel, 1.38"-10 Spline

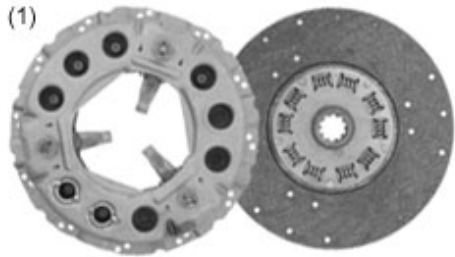

Features:

- Remanufactured Lipe Clutch Packs contain a remanufactured cover assembly and new disc assembly.
- Replacement disc assemblies available in new only.

Specifications:

Approximate Weight 44 lbs.

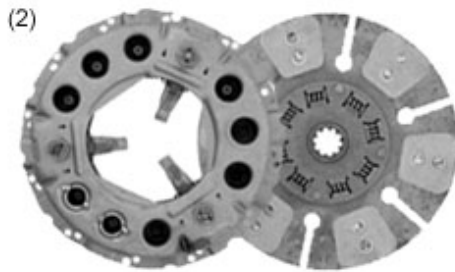

SKU#	Product Description	Cover Assembly	Disc Assembly	Disc Type	Max. Torque	Bolt Circle	Application	Pic. #	Core Group
RC1938124X	Reman. Push Type, Single Plate, Flat Flywheel, 1.38"-10 Spline	RC3301938X	1300091803	Damp Organic	350	14.125 14.625	Ford/Dodge	1	LP3301
RC1938127X	Reman. Push Type, Single Plate, Flat Flywheel, 1.38"-10 Spline	RC3301938X	1300091903	Damp Ceramic	350	14.125 14.625	Ford/Dodge	2	LP3301

Push Type, Single Plate

Flat Flywheel, 1.5"-10 Spline

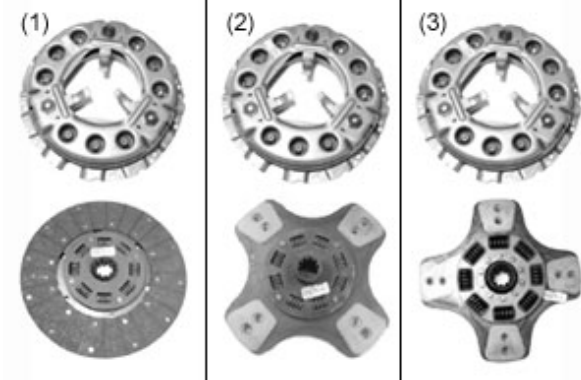

Features:

- Remanufactured Lipe Clutch Packs contain a remanufactured cover assembly and new disc assembly.
- Replacement disc assemblies available in new only.

Specifications:

Approximate Weight 45 lbs.

SKU#	Product Description	Cover Assembly	Disc Assembly	Disc Type	Max. Torque	Bolt Circle	Application	Pic. #	Core Group
RC1933134X	Reman. Push Type, Single Plate, Flat Flywheel	RC3301933X	1300091135	Damp Organic	350	14.125 14.625	Perkins	1	LP3301
RC1935136X	Reman. Push Type, Single Plate, Flat Flywheel	RC3301935X	3300091865	Damp Ceramic	500	375 mm 14.764	Renault	2	LP3301
RC1938134X	Reman. Push Type, Single Plate, Flat Flywheel	RC3301938X	1300091135	Damp Organic	350	14.125 14.625	Chevrolet GMC	1	LP3301
RC1938137X	Reman. Push Type, Single Plate, Flat Flywheel	RC3301938X	1300091904	Damp Ceramic	500	14.125 14.625	Chevrolet GMC	2	LP3301
RC2077136X	Reman. Push Type, Single Plate, Flat Flywheel	RC3302077X	3300092078	Damp Ceramic	500	14.125 14.625	CAT 3116 Engine CAT 3126 Engine	3	LP3301

Push Type, Single Plate

Flat Flywheel, 1.75"-10 Spline

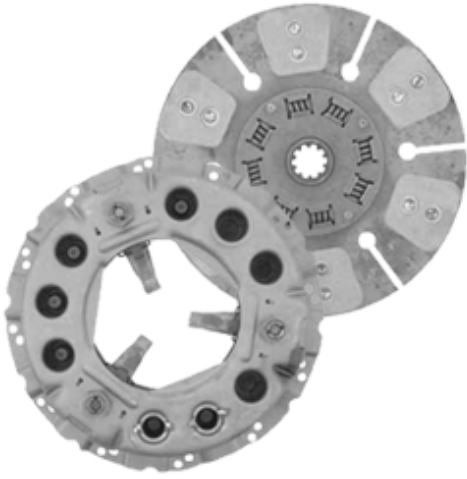

SKU#	Product Description	Cover Assembly	Disc Assembly	Disc Type	Max. Torque	Bolt Circle	Application	Approx. Weight	Core Group
RC2416146X	Reman. Push Type, Single Plate, Flat Flywheel, 1.75"-10 Spline, 13" Lipe Clutch Pack	3300612416	3300092425	Damp Ceramic	500	375mm 14.764	Various	46 lbs.	LP3301

Push Type, Two Plate

1.062 Recess Flywheel, 1.5"-10 Spline

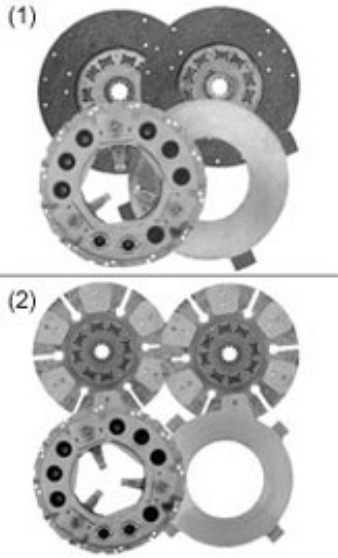

Features:

- Remanufactured Lipe Clutch Packs contain a remanufactured cover assembly, new disc assembly and new intermediate plate.

Specifications:

Approximate Weight 68 lbs.

Notes:

- 1) ** For Flat Flywheel must use **AK-315** Adapter Kit.
- 2) *** For Flat Flywheel must use **AK-316** Adapter Kit.

SKU#	Product Description	Cover Assy.	Disc Assy.	Intermed. Plate	Disc Type	Max. Torq.	Bolt Circle	Application	Pic. #	Core Group
RC1931134X	Reman. Push Type, Two Plate, 1.062** Recess Flywhl.	RC3301931X	1300091134 (FWS) 1300091135 (PPS)	C025-0094	Damp Organic	600	14.125 14.625	Cummins	1	LP3301
RC1937134X	Reman. Push Type, Two Plate, 1.062*** Recess Flywhl.	RC3301937X	1300091134 (FWS) 1300091135 (PPS)	C025-0094	Damp Organic	600	14.125 14.625	Chev-GMC Cummins	1	LP3301
RC1989134X	Reman. Push Type, Two Plate, 1.062** Recess Flywhl.	RC3301989X	1300091134 (FWS) 1300091135 (PPS)	C025-0094	Damp Organic	600	14.125 14.625	Navistar Ford	1	LP3301
RC1989138X	Reman. Push Type, Two Plate, 1.062** Recess Flywhl.	RC3301989X	1300091530 (FWS) 1300091531 (PPS)	C025-0094	Damp Ceramic	750	14.125 14.625	Navistar Ford	2	LP3301

Push Type, Two Plate

1.062 Recess Flywheel, 1.75"-10 Spline

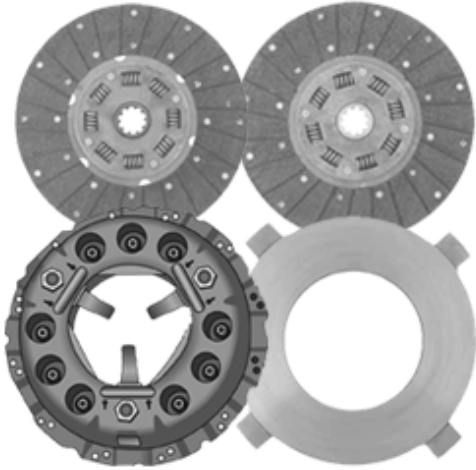

Features:

- Remanufactured Lipe Clutch Packs contain a remanufactured cover assembly, new disc assembly and new intermediate plate.

Specifications:

Approximate Weight 70 lbs.

Notes:

- 1) ** For Flat Flywheel must use **AK-315** Adapter Kit.

SKU#	Product Description	Cover Assembly	Disc Assemblies	Intermediate Plate	Disc Type	Max. Torque	Bolt Circle	Application	Core Group
RC1931144X	Reman. Push Type, Two Plate, 1.062** Recess Flywheel, 1.75"-10 Spline	RC3301931X	1300091136 (FWS) 1300091137 (PPS)	C025-0094	Damp Organic	600	14.125 14.625	Cummins	LP3301

Push Type, Two Plate

1.478 Recess Flywheel, 1.5"-10 Spline

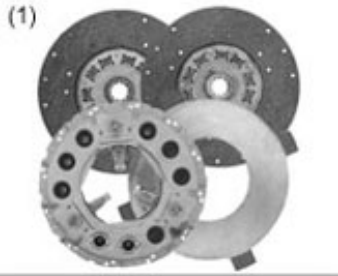

Features:

- Remanufactured Lipe Clutch Packs contain a remanufactured cover assembly, new disc assembly and new intermediate plate.

Specifications:

Approximate Weight 81 lbs.

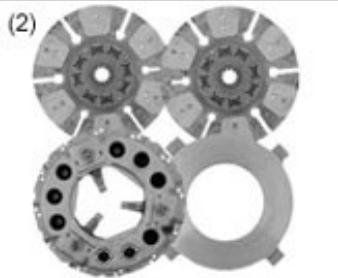

SKU#	Product Description	Cover Assy.	Disc Assy.	Intermed. Plate	Disc Type	Max. Torque	Bolt Circle	Application	Pic. #	Core Group
RC1940132X	Reman. Push Type, Two Plate, 1.478 Recess Flywheel, 1.5"-10 Spline	RC3301940X	1300060830	C025-0096	Rigid Organic	-	-	Ford Gas	1	LP3301
RC1940136X	Reman. Push Type, Two Plate, 1.478 Recess Flywheel, 1.5"-10 Spline	RC3301940X	1300091530 (FWS) 1300091531 (PPS)	C025-0096	Damp Ceramic	-	-	Ford Gas	2	LP3301
RC1941134X	Reman. Push Type, Two Plate, 1.478 Recess Flywheel, 1.5"-10 Spline	RC3301941X	1300091134 (FWS) 1300091135 (PPS)	C025-0094	Damp Organic	600	14.500	Cat 3208	1	LP3301

Pull Type, Two Plate

Flat Flywheel, 1.75"-10 Spline



Features:

- Remanufactured Lipe Clutch Packs contain a remanufactured cover assembly and new disc assembly.

Specifications:

Application CAT 3116 Engine (215 HP and up) and CAT 3126 Engine

Notes:

- 1) *** Original installation requires AK-313 Adapter Kit.
- 2) **LP2070546** and **RC2070546X** includes AK313 adapter ring.

SKU#	Product Description	Cover Assembly	Disc Assemblies	Intermediate Plate	Disc Type	Max. Torque	Bolt Circle	Approximate Weight	Core Group
RC2070146X	Reman. Pull Type, Two Plate, Flat*** Flywheel. 1.75-10 Spline	RC3302070X	3300092073M (FWS) 3300092074M (PPS)	C0250094	Damp Ceramic	750	14.125 14.625	77 lbs.	LP3302
RC2070546X	Reman. Pull Type, Two Plate, Flat Flywheel. 1.75-10 Spline - includes AK313 Adapter Ring	RC3302070X	3300092073M (FWS) 3300092074M (PPS)	C0250094	Damp Ceramic	750	14.125 14.625	87 lbs.	LP3302

Push Type, Single Plate

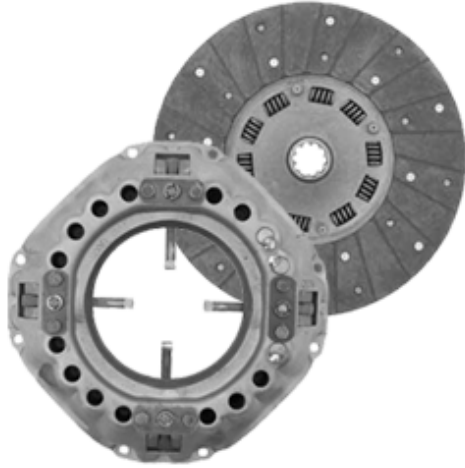

Features:

- Remanufactured

Notes:

- 1) Discs purchased separately are outright. No core charge/return applicable.

SKU#	Product Description	Cover Assembly	Disc Assembly	Disc Type	Spline Size	Approx. Weight	Application	Core Group
RC03860629KX	Remanufactured Single Plate, Push Type Clutch Pack	RCA0386X	RCD0629RX	Damp Kevlar	1-3/8" – 10T	34 lbs.	Ford	CA1301
RC05390094X	Remanufactured Single Plate, Push Type Clutch Pack	RCA0539X	RCD0094RX	Damp Organic	1-1/8" – 10T	35 lbs.	Chevrolet-GMC	CA1301
RC05390629X	Remanufactured Single Plate, Push Type Clutch Pack	RCA0539X	RCD0629RX	Damp Organic	1-3/8" – 10T	34 lbs.	Ford	CA1301

Push Type, Two Plate

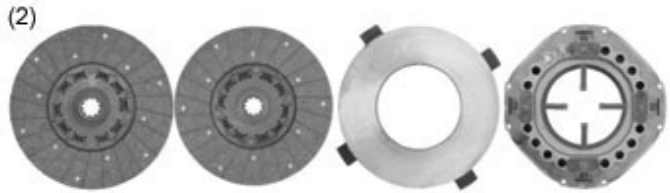
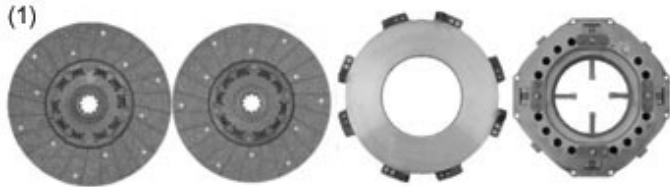

Specifications:

Reman. Cover Assembly RCA1014X

Notes:

- 1) RC7040999X requires AK313 adapter ring.

SKU#	Product Description	Disc Type	Spline Size	Approx. Weight	Application	Pic. #	Core Group
RC1014766X	Remanufactured Two Plate, Push Type Clutch Pack	Damp Organic (2)	1-1/2" - 10T	70 lbs.	Ford Gas, Flywheel Depth 1.477"	1	MU1303
RC7040999X	Remanufactured Two Plate, Push Type Clutch Pack	Damp Organic (2)	1-1/2" - 10T	59 lbs.	Ford, Cat Engine	2	MU1303

Push Type, Single Plate



Notes:

- 1) Discs are remanufactured.
- 2) Discs purchased separately are outright. No core charge/return applicable.

SKU#	Product Description	Cover Assembly	Disc Assembly	Disc Type	Spline Size	Approx. Weight	Application	Core Group
RC54355123X	Remanufactured Single Plate, Push Type Clutch Pack	RCA5435X	RCD5123RX	Damp Organic	1-1/2" – 10T	49 lbs.	Navistar	CA1301
RC54355210X	Remanufactured Single Plate, Push Type Clutch Pack	RCA5435X	RCD5210RX	Damp Organic	1-1/4" – 10T	49 lbs.	Navistar	CA1301

Pull Type, Single Plate



SKU#	Product Description	Disc Type	Spline Size	Approximate Weight	Application	Core Group
RC1477583X	Remanufactured Single Plate, (Diaphragm) Pull Type Clutch Pack	Damp Ceramic	1-3/4" - 10T	63 lbs.	Ford 7.8 L.	CA1402

14" COOL Standard Clutch Packs – Single Plate 08-CLUTCHES

14" COOL Standard Clutch Packs – Single Plate



SKU#	Product Description	Plate Load	Disc Springs	Disc Facing	Max. Torq.	Flywhl Dia.	Front Disc Flywhl Side	Pic. #
N10768316	New Single Plate, 1.75"-10 Spline, Angle Spring	3200	8	Organic	440	7"	N127262	1
N1076835	New Single Plate, 1.75"-10 Spline, Angle Spring	3200	8	3 Pad – CB	620	7"	N128276	2
N1079151	New Single Plate, 1.75"-10 Spline, Angle Spring	3200	8	4 Pad – CB	650	7"	N127405	3

14" COOL Standard Clutch Packs – Two Plate

(1)



(2)



(3)



Includes Adaptor Ring and Center Plate

SKU#	Product Description	Plate Load	Disc Springs	Disc Facing	Max. Torq.	Center Plate	Flywhl Dia.	Front Disc Flywhl Side	Rear Disc Press Plate Side	Pic. #
N10723710	New Two Plate, 1.75"-10 Spline, Angle Spring	2800	8	3 Pad VTL-CB	860	PL1480AR	7"	N128578	N128579	3
N10723722	New Two Plate, 1.75"-10 Spline, Angle Spring	2800	8	3 Pad - CB	860	PL1480AR	7"	N128275	N128276	2
N10723724	New Two Plate, 1.75"-10 Spline, Angle Spring	2800	8	4 Pad - CB	860	PL1480AR	7"	N127404	N127405	-
N10734222	New Two Plate, 2.0"-10 Spline, Angle Spring	2800	8	3 Pad - CB	900	PL1480AR	7"	N128231	N128232	2
N10734224	New Two Plate, 2.0"-10 Spline, Angle Spring	2800	8	4 Pad - CB	1000	PL1480AR	7"	N128229	N128230	-
N10770116	New Two Plate, 1.75"-10 Spline, Angle Spring	2800	8	Organic	800	PL1480AR	7"	N127261	N127262	1
N10770316	New Two Plate, 2.0"-10 Spline, Angle Spring	2800	8	Organic	800	PL1480AR	7"	N127273	N127274	1

14" COOL N EZ® Clutch Packs – Single Plate



COOL-N-EZ® Clutches are a direct replacement for Eaton/Spicer® Stamped Steel Angle Spring Clutch

SKU#	Product Description	Plate Load	Disc Springs	Disc Facing	Max. Torq.	Flywhl Dia.	Front Disc Flywhl Side	Pic. #
N10768316CE	New Single Plate, 1.75"-10 Spline, Angle Spring	3200	8	Organic	445	7"	N127262	-
N1076835CE	New Single Plate, 1.75"-10 Spline, Angle Spring	3200	8	3 Pad – CB	620	7"	N128276	2
N1076976CE	New Single Plate, 1.75"-10 Spline, Angle Spring	3200	8	6 Pad VTL-CB	680	7"	N128573	-
N1079151CE	New Single Plate, 1.75"-10 Spline, Angle Spring	3200	8	4 Pad – CB	650	7"	N127405	3

14" COOL N EZ® Clutch Packs – Two Plate

(1)



(2)



(3)



Includes Adaptor Ring and Center Plate
COOL-N-EZ® Clutches are a direct replacement for
Eaton/Spicer® Stamped Steel Angle Spring Clutch

SKU#	Product Description	Plate Load	Disc Springs	Disc Facing	Max. Torq.	Center Plate	Flywhl Dia.	Front Disc Flywhl Side	Rear Disc Press Plate Side	Pic. #
N10723710CE	New Two Plate, 1.75"-10 Spline, Angle Spring	2800	8	3 Pad VTL-CB	860	PL1480AR	7"	N128578	N128579	3
N10723722CE	New Two Plate, 1.75"-10 Spline, Angle Spring	2800	8	3 Pad - CB	860	PL1480AR	7"	N128275	N128276	2
N10723724CE	New Two Plate, 1.75"-10 Spline, Angle Spring	2800	8	4 Pad - CB	860	PL1480AR	7"	N127404	N127405	-
N10734222CE	New Two Plate, 2.0"-10 Spline, Angle Spring	2800	8	3 Pad - CB	900	PL1480AR	7"	N128231	N128232	-
N10734224CE	New Two Plate, 2.0"-10 Spline, Angle Spring	2800	8	4 Pad - CB	1000	PL1480AR	7"	N128229	N128230	-
N1073424CE	New Two Plate, 2.0"-10 Spline, Angle Spring	2800	8	3 Pad VTL - CB	860	PL1480AR	7"	N128594	N128595	3
N10770116CE	New Two Plate, 1.75"-10 Spline, Angle Spring	2800	8	Organic	800	PL1480AR	7"	N128238	N128239	1
N10770316CE	New Two Plate, 2.0"-10 Spline, Angle Spring	2800	8	Organic	800	PL1480AR	7"	N127273	N127274	1

14" EZ N LITE® Clutch Packs

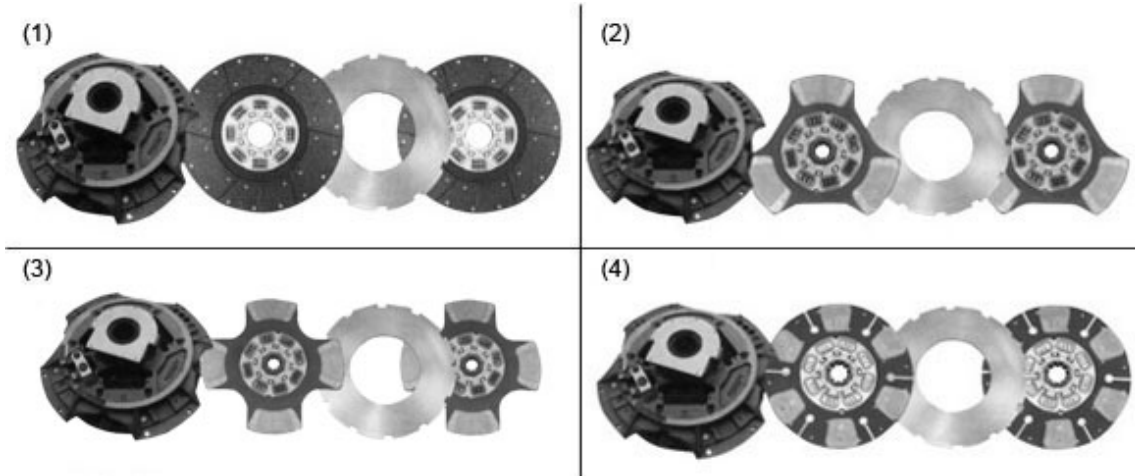

Note: *Carbotic® (Wellman Friction Products)
EZ-N-LITE® Clutches are a direct replacement for Eaton/Spicer® EZ Pedal®

SKU#	Product Description	Plate Load	Disc Springs	Disc Facing	Max. Torq.	Center Plate	Flywhl Dia.	Front Disc Flywhl Side	Rear Disc Press Plate Side	Pic. #
N10803461	New Two Plate, 2.0"-10 Spline, Angle Spring	3600	8	3 Pad - CB	1000	PL1603	7"	N128231	N128232	2
N10803482	New Two Plate, 2.0"-10 Spline, Angle Spring	3600	8	Organic	1150	PL1603	7"	N127273	N127274	1
N10803490	New Two Plate, 2.0"-10 Spline, Angle Spring	3600	8	6 Pad - CB	1400	PL1603	7"	N128101	N128102	4
N10803553	New Two Plate, 1.75"-10 Spline, Angle Spring	3600	8	3 Pad - CB	1000	PL1603	7"	N128275	N128276	2
N10803582	New Two Plate, 1.75"-10 Spline, Angle Spring	3600	8	Organic	1150	PL1603	7"	N127261	N127262	1
N10803590	New Two Plate, 1.75"-10 Spline, Angle Spring	3600	8	6 Pad - CB	1400	PL1603	7"	N128099	N128100	-
N10805059	New Two Plate, 2.0"-10 Spline, Angle Spring	3600	8	4 Pad - CB	1400	PL1603	7"	N128229	N128230	3
N10805059C	New Two Plate, 2.0"-10 Spline, Angle Spring	3600	8	4 Pad - Carbotic*	1400	PL1603	7"	N128229C	N128230C	3
N10806359	New Two Plate, 1.75"-10 Spline, Angle Spring	3600	8	4 Pad - CB	1250	PL1603	7"	N127404	N127405	3

Pull Type, Single Plate

Flat Flywheel, 1.75"-10/2.0"-10 Spline

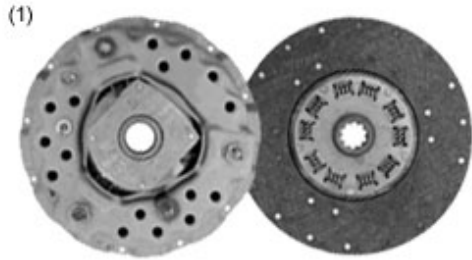

Features:

- Reman. Lipe Clutch Packs contain a remanufactured cover assembly and new disc assembly.

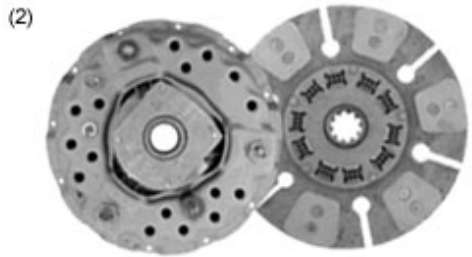

SKU#	Product Description	Cover Assembly	Disc Assembly	Disc Type	Max. Torque	Bolt Circle	Approx. Weight	Application	Pic. #	Core Group
RC1760646X	Reman. 14" Pull Type, Single Plate, Flat Flywheel, 2"-10 Spline	RC141760X	1400092302	Damp Ceramic	650	15.500	51 lbs.	Various	2	LP1402
RC1854604X	Reman. Pull Type, Single Plate, Flat Flywheel, 1.75"-10 Spline	RC141854X	1400092213	Damp Organic	500	15.500	70 lbs.	Various	1	LP1402
RC1854618X	Reman. Pull Type, Single Plate, Flat Flywheel, 1.75"-10 Spline	RC141854X	1400092211	Damp Ceramic	650	15.500	66 lbs.	Various	2	LP1402

Pull Type, Two Plate

2.937 Recess Flywheel, 1.75"-10 Spline

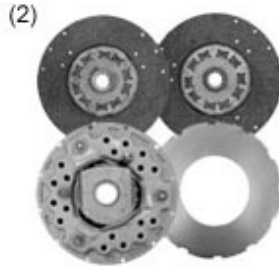
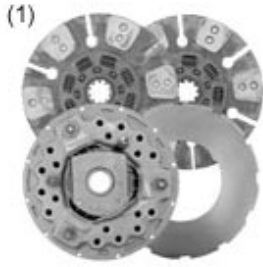

Features:

- Remanufactured Lipe Clutch Packs contain a remanufactured cover assembly, new disc assemblies and new intermediate plate.

Specifications:

Approximate Weight 100 lbs.

SKU#	Product Description	Cover Assy.	Disc Assy.	Intermed. Plate	Disc Type	Max. Torq.	Bolt Circle	App.	Pic. #	Core Group
RC1707607X	Reman. Pull Type, Two Plate, 2.937 Recess Flywheel, 1.75"-10 Spline	RC141707X	1400092212 1400092213	C0250070	Damp Organic	1350	15.500	Chevrolet GMC Ford Navistar	2	LP1402
RC1777607X	Reman. Pull Type, Two Plate, 2.937 Recess Flywheel, 1.75"-10 Spline	RC141777X	1400092303 1400092304	C0250070	Damp Organic	1300	15.500	Chevrolet GMC Ford Navistar	2	LP1402
RC1777608X	Reman. Pull Type, Two Plate, 2.937 Recess Flywheel, 1.75"-10 Spline	RC141777X	1400092299 1400092300	C0250070	Damp Ceramic	1300	15.500	Chevrolet GMC Ford Navistar	1	LP1402

Pull Type, Two Plate

2.937 Recess Flywheel, 2.0"-10 Spline

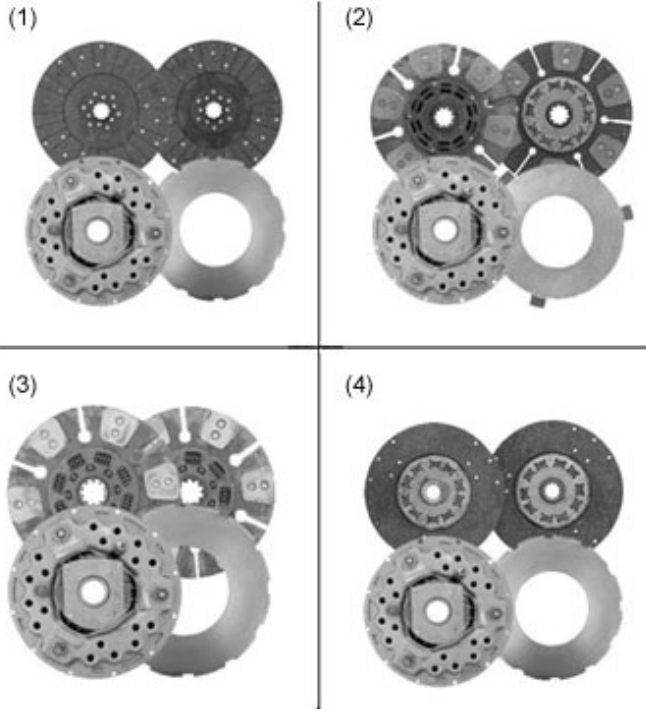

Features:

- Remanufactured Lipe Clutch Packs contain a remanufactured cover assembly, new disc assemblies and new intermediate plate.

Specifications:

Bolt Circle 15.500

SKU#	Product Description	Cover Assy.	Disc Assy.	Intermed. Plate	Disc Type	Max. Torq.	Approx. Weight	App.	Pic. #	Core Group
RC1760706X	Reman. Pull Type, Two Plate, 2.937 Recess Flywheel, 2.0"-10 Spline	RC141778X	1400092301 1400092302	C0250082	Damp Cer.	1200	51 lbs.	DDC	2	LP1402
RC1767608X	Reman. Pull Type, Two Plate, 2.937 Recess Flywheel, 2.0"-10 Spline	RC141767X	1400092301 1400092302	C0250070	Damp Cer.	1300	51 lbs.	Chev. GMC Ford Nav.	3	LP1402
RC1778607X	Reman. Pull Type, Two Plate, 2.937 Recess Flywheel, 2.0"-10 Spline	RC141778X	1400092305 1400092306	C0250070	Damp Org.	900	97 lbs.	Chev. GMC Ford Nav.	4	LP1402
RC1778608X	Reman. Pull Type, Two Plate, 2.937 Recess Flywheel, 2.0"-10 Spline	RC141778X	1400092301 1400092302	C0250070	Damp Cer.	1300	96 lbs.	Chev. GMC Ford Nav.	3	LP1402
RC1778641X	Reman. Pull Type, Two Plate, 2.937 Recess Flywheel, 2.0"-10 Spline	RC141778X	DK241	C0250070	Spline Saver (Rigid Org.)	900	56 lbs.	Chev. GMC Ford Nav.	1	LP1402

Pull Type, Two Plate

Flat Flywheel, 1.75"-10 Spline

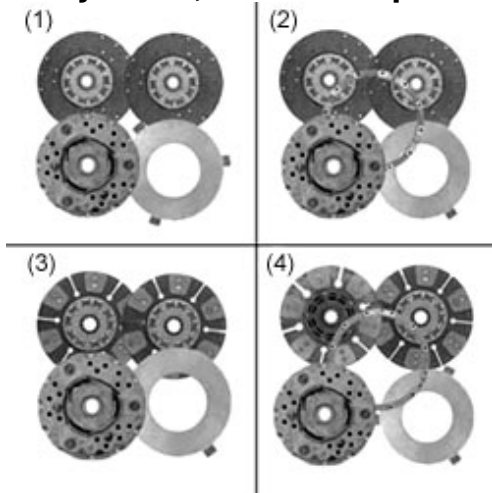

Features:

- Remanufactured Lipe Clutch Packs contain a remanufactured cover assembly, new disc assemblies and new intermediate plate.

Specifications:

Approximate Weight 107 lbs.

Notes:

- 1) **Flat Flywheel application requires **AK-285** Adapter Kit.

SKU#	Product Description	Cover Assy.	Disc Assy.	Intermed. Plate	Disc Type	Max. Torq.	Bolt Circle	App.	Pic. #	Core Group
RC1714604X	Reman. Pull Type, Two Plate, Flat Flywheel, 1.75"-10 Spline	RC141714X	1400092212 (FWS) 1400092213 (PPS)	C0250082	Damp Organic	1440	-	Chevrolet GMC Ford Navistar	1	LP1402
RC1714618X	Reman. Pull Type, Two Plate, Flat Flywheel, 1.75"-10 Spline	RC141714X	1400092210 (FWS) 1400092211 (PPS)	C0250082	Damp Ceramic	1850	-	Chevrolet GMC Ford Navistar	3	LP1402
RC1714704X	Reman. Pull Type, Two Plate, Flat Flywheel, 1.75"-10 Spline with Adapter Ring AK285	RC141714X	1400092212 (FWS) 1400092213 (PPS)	C0250082	Damp Organic	1440	-	Chevrolet GMC Ford Navistar	2	LP1402
RC1714718X	Reman. Pull Type, Two Plate, Flat Flywheel, 1.75"-10 Spline with Adapter Ring AK285	RC141714X	1400092210 (FWS) 1400092211 (PPS)	C0250082	Damp Ceramic	1850	-	Chevrolet GMC Ford Navistar	4	LP1402

Push Type, Single Plate

1.187 Recess Flywheel, 1.5"-10 Spline



Features:

- Reman. Lipe Clutch Packs contain a remanufactured cover assembly and new disc assembly.
- Replacement disc assemblies available in new only.

Specifications:

Approximate Weight 51 lbs.

SKU#	Product Description	Cover Assembly	Disc Assembly	Disc Type	Max. Torque	Bolt Circle	Application	Core Group
RC1076604X	Reman. Push Type, Single Plate, 1.187 Recess Flywheel, 1.5"-10 Spline	RC141076X	1400091027	Damp Organic	500	14.750	Ford-Mack	LP1401

Push Type, Single Plate

Flat Flywheel, 1.5"-10 Spline

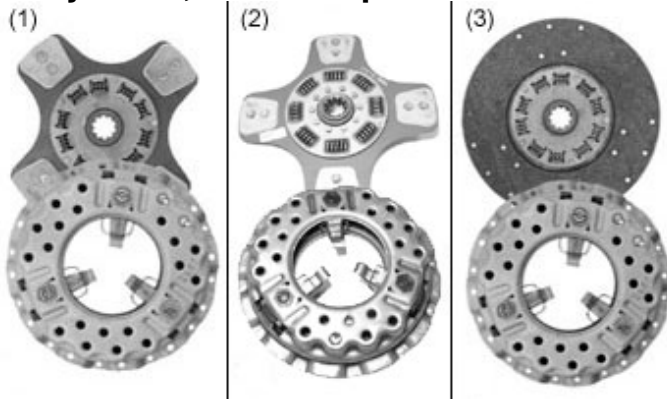

Features:

- Reman. Lipe Clutch Packs contain a remanufactured cover assembly and new disc assembly.
- Replacement disc assemblies available in new only.

Specifications:

Approximate Weight 55 lbs.

SKU#	Product Description	Cover Assembly	Disc Assembly	Disc Type	Max. Torque	Bolt Circle	Application	Picture Number	Core Group
RC1047604X	Reman. Push Type, Single Plate, Flat Flywheel, 1.5"-10 Spline	RC141047X	1400091027	Damp Organic	500	15.500	Chevrolet GMC Ford	3	LP1401
RC1086604X	Reman. Push Type, Single Plate, Flat Flywheel, 1.5"-10 Spline	RC141086X	1400091027	Damp Organic	500	15.500	Navistar	3	LP1401
RC1686607X	Reman. Push Type, Single Plate, Flat Flywheel, 1.5"-10 Spline	RC141686X	1400092208	Damp Ceramic	500	15.500	Chevrolet GMC Diesel	2	LP1401
RC1686640X	Reman. Push Type, Single Plate, Flat Flywheel, 1.5"-10 Spline	RC141686X	1400091998	Damp Ceramic	550	15.500	Chevrolet GMC Gas	1	LP1401

Push Type, Single Plate

Flat Flywheel, 1.75"-10 Spline

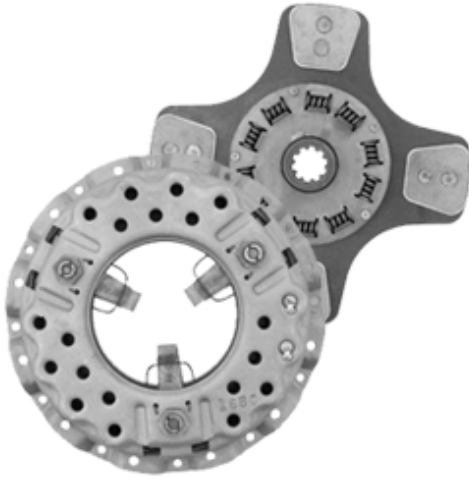

Features:

- Reman. Lipe Clutch Packs contain a remanufactured cover assembly and new disc assembly.
- Replacement disc assemblies available in new only.

Specifications:

Approximate Weight 57 lbs.

SKU#	Product Description	Cover Assembly	Disc Assembly	Disc Type	Max. Torque	Bolt Circle	Application	Pic. #	Core Group
RC1113646X	Reman. Push Type, Single Plate, Flat Flywheel, 1.75"-10 Spline	RC141113X	1400092211	Damp Ceramic	500	15.500	Chevrolet-GMC, 3116 Cat	4	LP1401

Push Type, Two Plate

1.062 Recess Flywheel, 1.5"-10 Spline

(1)



(2)



Features:

- Reman. Lipe Clutch Packs contain a remanufactured cover assembly, new disc assemblies and new intermediate plate.

Specifications:

Application Ford
Approximate Weight 87 lbs.

Notes:

- 1) ** For Flat Flywheel must use **AK-208** Adapter Kit.

SKU#	Product Description	Cover Assembly	Disc Assemblies	Intermediate Plate	Disc Type	Max. Torque	Bolt Circle	Pic. #	Core Group
RC1072604X	Reman. Push Type, Two Plate, 1.062** Recess Flywheel, 1.50"-10 Spline	RC141072X	1400092355 (FWS) 1400092356 (PPS)	C0250100	Damp Organic	600	15.500	1	LP1401
RC1072607X	Reman. Push Type, Two Plate, 1.062** Recess Flywheel, 1.5"-10 Spline	RC141072X	1400092357 (FWS) 1400092208 (PPS)	C0250100	Damp Ceramic	900	15.500	2	LP1401

Push Type, Two Plate

1.093 Recess Flywheel, 1.75"-10 Spline

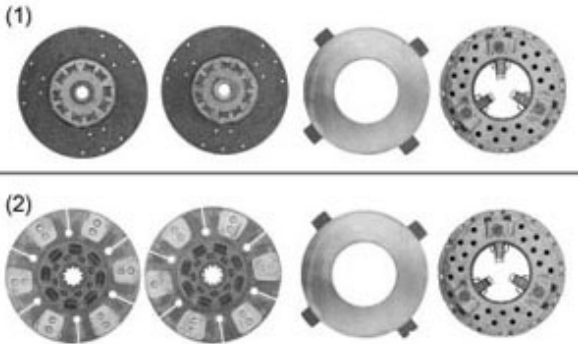

Features:

- Reman. Lipe Clutch Packs contain a remanufactured cover assembly, new disc assemblies and new intermediate plate.

Specifications:

Approximate Weight 88 lbs.

Notes:

- 1) ** For Flat Flywheel must use **AK-208** Adapter Kit.

SKU#	Product Description	Cover Assy.	Disc Assy.	Intermed. Plate	Disc Type	Max. Torque	Bolt Circle	Application	Pic. #	Core Group
RC1067645X	Reman. Push Type, Two Plate, 1.093** Recess Flywheel	RC141067X	1400092303 (FWS) 1400092304 (PPS)	C0250100	Damp Organic	1000	15.625	Various Crane	1	LP1401
RC1067646X	Reman. Push Type, Two Plate, 1.093** Recess Flywheel	RC141067X	1400092299 (FWS) 1400092300 (PPS)	C0250100	Damp Ceramic	1200	15.625	Various Crane	2	LP1401
RC1113604X	Reman. Push Type, Two Plate, 1.093** Recess Flywheel	RC141113X	1400092212 (FWS) 1400092213 (PPS)	C0250100	Damp Organic	750	15.500	Chevrolet GMC	1	LP1401
RC1113606X	Reman. Push Type, Two Plate, 1.093** Recess Flywheel	RC141113X	1400092210 (FWS) 1400092211 (PPS)	C0250100	Damp Ceramic	1000	15.500	Chevrolet GMC	2	LP1401
RC1113649X	Reman. Push Type, Two Plate, 1.093** Recess Flywheel	RC141113X	1400092303 (FWS) 1400092304 (PPS)	C0250100	Damp Organic	750	15.500	Caterpillar	1	LP1401

Push Type, Single Plate



Notes:

- 1) Discs are remanufactured.
- 2) Discs purchased separately are outright. No core charge/return applicable.

SKU#	Product Description	Cover Assembly	Disc Assembly	Disc Type	Spline Size	Approx. Weight	Application	Core Group
RC06321001X	Remanufactured Single Plate, Push Type Clutch Pack	RCA0632X	RCD1001RX	Rigid Organic	1-1/2" – 10T	35 lbs.	Ford	CA1402

Push Type, Two Plate



Typical

SKU#	Product Description	Disc Type	Spline Size	Approximate Weight	Application	Core Group
RC0588756X	Remanufactured Two Plate, Push Type Clutch Pack	Damp Organic	1-1/2" - 10T	87 lbs.	Ford, Cat Engine	CA1402

Push Type, Single Plate



Notes:

- 1) Discs are remanufactured.
- 2) Discs purchased separately are outright. No core charge/return applicable.

SKU#	Product Description	Cover Assembly	Disc Assembly	Disc Type	Spline Size	Approx. Weight	Application	Core Group
RC54245139X	Remanufactured Single Plate, Push Type Clutch Pack	RCA5424X	RCD5139RX	Damp Organic	1-1/2" – 10T	50 lbs.	Navistar, Dodge	CA1402

Pull Type, Single Plate

Flat Flywheel, 1.75"-10 Spline



Notes:

- 1) Spicer Type "RC" Clutch Packs contain remanufactured cover assembly, new disc assemblies and resurfaced intermediate plate.

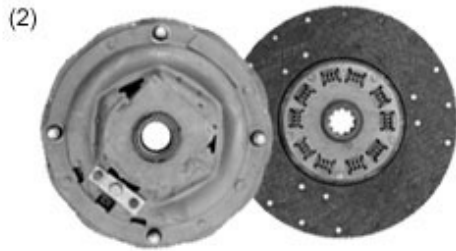

SKU#	Product Description	Disc Type	Max. Torque	Approx. Weight	Application	Pic. #	Core Group
RC747DCX	Reman. Pull Type, Single Plate, Flat Flywheel, 1.75"-10 Spline	Damp Ceramic	900	70 lbs.	Ford Navistar	1	MU1404
RC747DOX	Reman. Pull Type, Single Plate, Flat Flywheel, 1.75"-10 Spline	Damp Organic	800	72 lbs.	Ford Navistar	2	MU1404

Pull Type, Two Plate

Flat Flywheel, 1.75"-10/2.0"-10 Spline



Pull Type, Two Plate

2.937 Recess Flywheel, 1.75"-10 Spline



Features:

- Easy-Pedal™ designated by EZ in Part Number

Specifications:

Cover Type Cast
Application Various

Notes:

- 1) Contains remanufactured cover assembly, new disc assemblies and resurfaced intermediate plate.

SKU#	Product Description	Max. Torque	Disc Type	Approx. Weight	Pic. #	Core Group
RC400DCX	Standard Reman. Pull Type, Two Plate, 2.937" Recess Flywheel, 1.75"-10 Spline	1400	Damp Ceramic	104 lbs.	2	MU1403
RC400DOX	Standard Reman. Pull Type, Two Plate, 2.937" Recess Flywheel, 1.75"-10 Spline	1150	Damp Organic	103 lbs.	1	MU1403
RC400EZDCX	Standard Reman. Pull Type, Two Plate, 2.937" Recess Flywheel, 1.75"-10 Spline	1400	Damp Ceramic	105 lbs.	2	MU1405
RC400EZDOX	Standard Reman. Pull Type, Two Plate, 2.937" Recess Flywheel, 1.75"-10 Spline	1150	Damp Organic	109 lbs.	1	MU1405
RC400ROX	Standard Reman. Pull Type, Two Plate, 2.937" Recess Flywheel, 1.75"-10 Spline	1000	Rigid Organic	96 lbs.	3	MU1403

Pull Type, Two Plate

2.937 Recess Flywheel, 2.0"-10 Spline

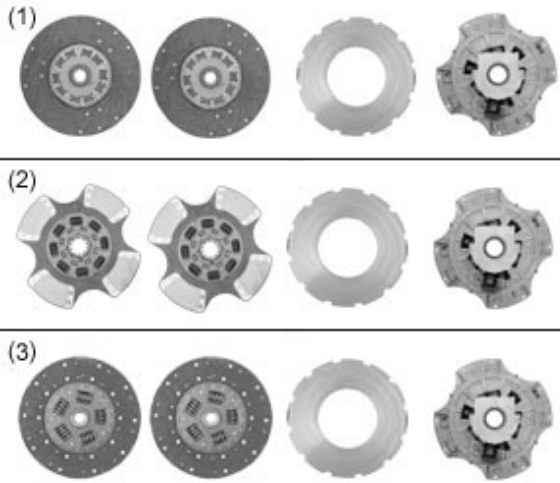

Features:

- Carbotic® (Wellman Friction Products)
- Kevlar® (Dupont Corporation)
- Easy-Pedal™ designated by EZ in Part Number

Specifications:

Cover Type Cast
Application Various

Notes:

- 1) Remanufactured clutch packs contains remanufactured cover assembly, new disc assemblies and resurfaced intermediate plate.

SKU#	Product Description	Max. Torque	Disc Type	Approximate Weight	Pic. #	Core Group
RC390CX	Standard Reman. Pull Type, Two Plate, 2.937 Recess Flywheel, 2.0"-10 Spline	1400	Damp Carbotic	103 lbs.	2	MU1403
RC390DCX	Standard Reman. Pull Type, Two Plate, 2.937 Recess Flywheel, 2.0"-10 Spline	1400	Damp Ceramic	103 lbs.	2	MU1403
RC390DOX	Standard Reman. Pull Type, Two Plate, 2.937 Recess Flywheel, 2.0"-10 Spline	1150	Damp Organic	104 lbs.	1	MU1403
RC390EZCX	Standard Reman. Pull Type, Two Plate, 2.937 Recess Flywheel, 2.0"-10 Spline	1400	Damp Carbotic	104 lbs.	2	MU1405
RC390EZDCX	Standard Reman. Pull Type, Two Plate, 2.937 Recess Flywheel, 2.0"-10 Spline	1400	Damp Ceramic	108 lbs.	2	MU1405
RC390EZDOX	Standard Reman. Pull Type, Two Plate, 2.937 Recess Flywheel, 2.0"-10 Spline	1150	Damp Organic	106 lbs.	1	MU1405
RC390EZKX	Standard Reman. Pull Type, Two Plate, 2.937 Recess Flywheel, 2.0"-10 Spline	-	Damp Kevlar	103 lbs.	2	MU1405
RC390KX	Standard Reman. Pull Type, Two Plate, 2.937 Recess Flywheel, 2.0"-10 Spline	-	Damp Kevlar	103 lbs.	2	MU1403
RC390ROX	Standard Reman. Pull Type, Two Plate, 2.937 Recess Flywheel, 2.0"-10 Spline	1000	Rigid Organic	98 lbs.	3	MU1403

Pull Type, Two Plate

2.937 Recess Flywheel, 1.75"-10 Spline



Specifications:

Application Various

Notes:



1) Contains remanufactured cover assembly, new premium disc assemblies and new intermediate plate.



SKU#	Product Description	Max. Torque	Disc Type	Approx. Weight	Picture Number	Core Group
MU400DCX	Premium Reman. Pull Type, Two Plate, 2.937" Recess Flywheel, 1.75"-10 Spline	1400	Damp Ceramic	104 lbs.	2	MU1403
MU400DOX	Premium Reman. Pull Type, Two Plate, 2.937" Recess Flywheel, 1.75"-10 Spline	1150	Damp Organic	102 lbs.	1	MU1403
MU400ROX	Premium Reman. Pull Type, Two Plate, 2.937" Recess Flywheel, 1.75"-10 Spline	1000	Rigid Organic	102 lbs.	3	MU1403
MU400SSCX	Premium Reman. Pull Type, Two Plate, 2.937" Recess Flywheel, 1.75"-10 Spline	1150	Rigid Ceramic Spline Saver	100 lbs.	2	MU1403
MU400SSOX	Premium Reman. Pull Type, Two Plate, 2.937" Recess Flywheel, 1.75"-10 Spline	1000	Rigid Organic Spline Saver	100 lbs.	3	MU1403

Pull Type, Two Plate

2.937 Recess Flywheel, 2.0"-10 Spline

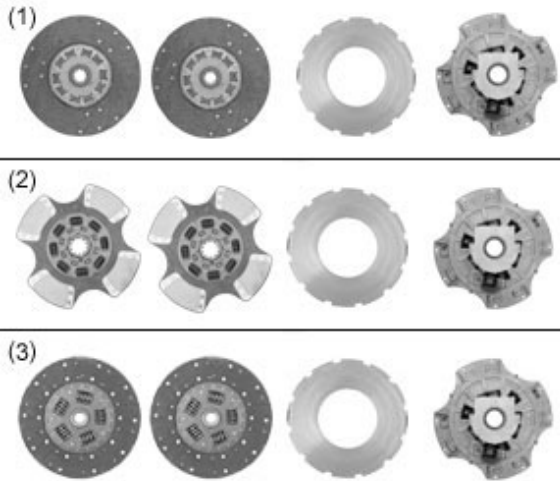

Features:

- Carbotic® (Wellman Friction Products)
- Kevlar® (Dupont Corporation)
- Easy-Pedal™ designated by EZ in Part Number

Specifications:

Application Various

Notes:

- 1) Contains remanufactured cover assembly, new premium disc assemblies and new intermediate plate.

SKU#	Product Description	Max. Torque	Disc Type	Approx. Weight	Picture Number	Core Group
MU390CX	Premium Reman. Pull Type, Two Plate, 2.937" Recess Flywheel, 2.0"-10 Spline	1400	Damp Carbotic	103 lbs.	2	MU1403
MU390DCX	Premium Reman. Pull Type, Two Plate, 2.937" Recess Flywheel, 2.0"-10 Spline	1400	Damp Ceramic	102 lbs.	2	MU1403
MU390DOX	Premium Reman. Pull Type, Two Plate, 2.937" Recess Flywheel, 2.0"-10 Spline	1150	Damp Organic	102 lbs.	1	MU1403
MU390EZCX	Premium Reman. Pull Type, Two Plate, 2.937" Recess Flywheel, 2.0"-10 Spline	1400	Damp Carbotic	108 lbs.	2	MU1405
MU390EZDCX	Premium Reman. Pull Type, Two Plate, 2.937" Recess Flywheel, 2.0"-10 Spline	1400	Damp Ceramic	106 lbs.	2	MU1405
MU390EZDOX	Premium Reman. Pull Type, Two Plate, 2.937" Recess Flywheel, 2.0"-10 Spline	1150	Damp Organic	106 lbs.	1	MU1405
MU390EZKX	Premium Reman. Pull Type, Two Plate, 2.937" Recess Flywheel, 2.0"-10 Spline	-	Damp Kevlar	108 lbs.	2	MU1405
MU390KX	Premium Reman. Pull Type, Two Plate, 2.937" Recess Flywheel, 2.0"-10 Spline	-	Damp Kevlar	103 lbs.	2	MU1403
MU390ROX	Premium Reman. Pull Type, Two Plate, 2.937" Recess Flywheel, 2.0"-10 Spline	1000	Rigid Organic	102 lbs.	3	MU1403
MU390SSCX	Premium Reman. Pull Type, Two Plate, 2.937" Recess Flywheel, 2.0"-10 Spline	1150	Rigid Ceramic Spline Saver	100 lbs.	2	MU1403
MU390SSOX	Premium Reman. Pull Type, Two Plate, 2.937" Recess Flywheel, 2.0"-10 Spline	1000	Rigid Organic Spline Saver	100 lbs.	3	MU1403

14" Standard Clutch Pack – Spicer Type

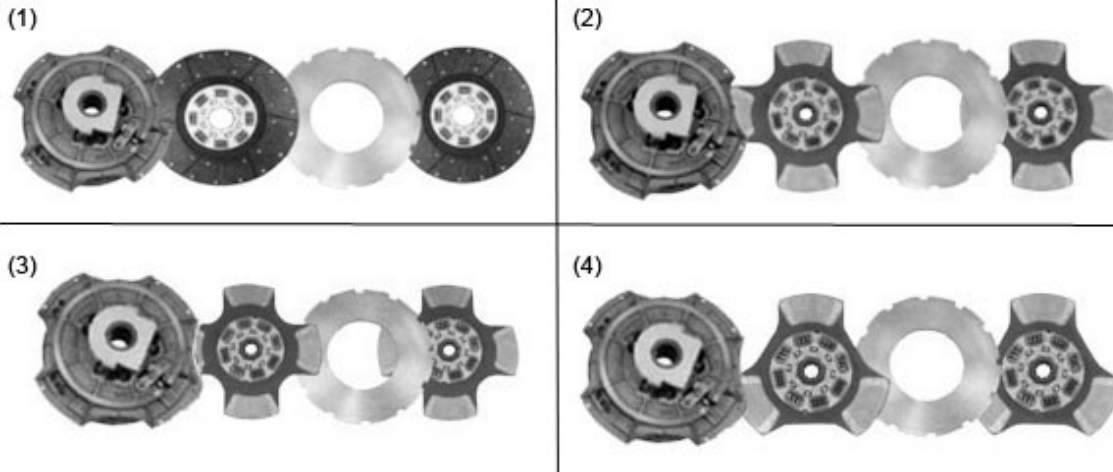

Note: *Carbotic® (Wellman Friction Products)

SKU#	Product Description	Plate Load	Disc Springs	Disc Facing	Max. Torq.	Center Plate	Flywhl Dia.	Front Disc Flywhl Side	Rear Disc Press Plate Side	Pic. #
N10703461	New Two Plate, 2.0"-10 Spline, Angle Spring	3200	8	3 Pad – CB	1000	PL1603	7"	N128231	N128232	4
N10703482	New Two Plate, 2.0"-10 Spline, Angle Spring	3200	8	Organic	1150	PL1603	7"	N127273	N127274	1
N10703582	New Two Plate, 1.75"-10 Spline, Angle Spring	3200	8	Organic	1150	PL1603	7"	N127261	N127262	1
N10705059	New Two Plate, 2.0"-10 Spline, Angle Spring	3200	8	4 Pad – CB	1400	PL1603	7"	N128229	N128230	2
N10705059C	New Two Plate, 2.0"-10 Spline, Angle Spring	3200	8	4 Pad – Carbotic*	1400	PL1603	7"	N128229C	N128230C	2
N10706359	New Two Plate, 1.75"-10 Spline, Angle Spring	3200	8	4 Pad – CB	1250	PL1603	7"	N127404	N127405	3

15-1/2" AUTO N EZ® Self Adjusting Clutches



Features:

- Self-adjusting feature that WORKS!
 - Flat torsion spring provides constant force
 - No hook coil spring
- The clutch that thinks like a mechanic!
 - It adjusts automatically!

SKU#	Product Description	Plate Load	Disc Springs	Disc Facing	Max. Torq.	Center Plate	Flywhl Dia.	Front Disc Flywhl Side	Rear Disc Press Plate Side
N10970061	New Two Plate, 2.0"-10 Spline, Angle Spring	3600	9	4 Pad – CB	1760	PL1632	10"	N128362	N128363
N10970078	New Two Plate, 2.0"-10 Spline, Angle Spring	4000	10	Organic	1450	PL1632	8.5"	N128445	N128446
N10970092	New Two Plate, 2.0"-10 Spline, Angle Spring	3600	9	6 Pad – CB	1760	PL1632	10"	N128537	N128538
N10970092HTM	New Two Plate, 2.0"-10 Spline, Angle Spring – TORQUEMONSTER (Mack)	4000	9	6 Pad – CB	2250	PL1632	10"	N128570	N128571H
N10970120TM	New Two Plate, 2.0"-10 Spline, Angle Spring – TORQUEMONSTER	4000	7 NVL	6 Pad – CB	1860	PL1632	10"	N128708TM	N128708TM
N10970125HTM	New Two Plate, 2.0"-10 Spline, Angle Spring – TORQUEMONSTER	4000	7 NVL	6 Pad – CB	2250	PL1632	10"	N128709HTM	N128709HTM
N10970125TM	New Two Plate, 2.0"-10 Spline, Angle Spring – TORQUEMONSTER	4000	7 NVL	6 Pad – CB	2050	PL1632	10"	N128709TM	N128709TM
N10970130TM	New Two Plate, 2.0"-10 Spline, Angle Spring – TORQUEMONSTER	4000	7 PDHT	6 Pad – CB	1860	PL1632	10"	N128716TM	N128716TM
N10970135HTM	New Two Plate, 2.0"-10 Spline, Angle Spring – TORQUEMONSTER	4000	7 PDHT	6 Pad – CB	2250	PL1632	10"	N128717HTM	N128717HTM
N10970135TM		4000	7 PDHT		2050	PL1632	10"	N128717TM	N128717TM

08-CLUTCHES

15-1/2" AUTO N EZ® Self Adjusting Clutches

	New Two Plate, 2.0"-10 Spline, Angle Spring – TORQUEMONSTER			6 Pad – CB					
N10970174	New Two Plate, 2.0"-10 Spline, Angle Spring	3600	10	4 Pad – CB	1650	PL1632	8.5"	N128257	N128258
N10970181	New Two Plate, 2.0"-10 Spline, Angle Spring	3600	8	4 Pad – CB	1400	PL1632	7"	N128215	N128216
N10970182	New Two Plate, 2.0"-10 Spline, Angle Spring	3600	7	4 Pad – CB	1700	PL1632	10"	N128462	N128462
N10970185	New Two Plate, 2.0"-10 Spline, Angle Spring	3600	7	6 Pad – CB	1700	PL1632	10"	N129462	N129462
N10970193	New Two Plate, 2.0"-10 Spline, Angle Spring	4000	10	6 Pad – CB	1860	PL1632	8.5"	N128539	N128540
N10970277	New Two Plate, 2.0"-10 Spline, Angle Spring	3600	8	Organic	1250	PL1632	7"	N127817	N127818

15-1/2" EZ N LITE® Clutch Packs

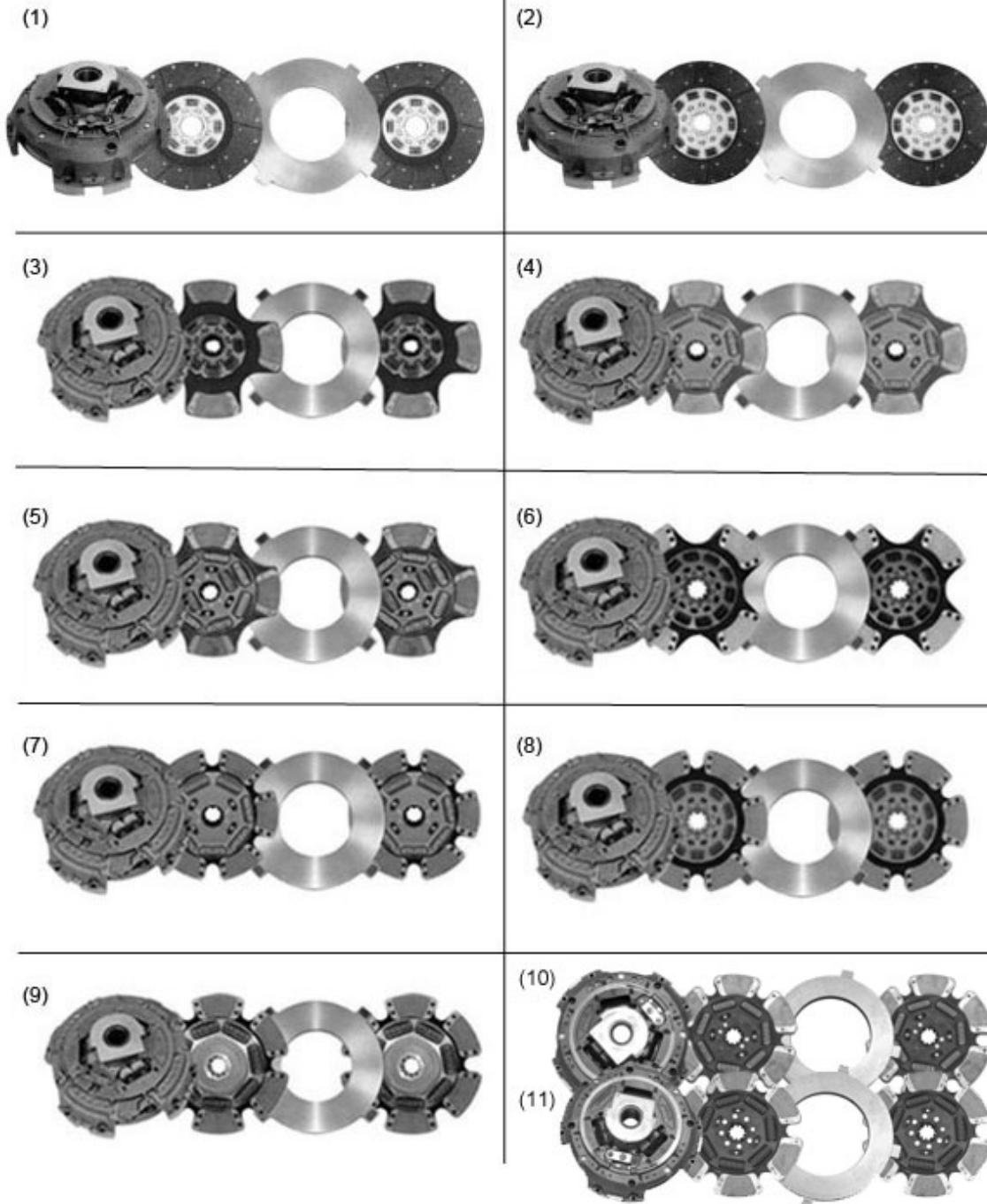

Note: *Carbotic® (Wellman Friction Products)
EZ-N-LITE® Clutches are a direct replacement for Eaton/Spicer® EZ Pedal®

08-CLUTCHES

15-1/2" EZ N LITE® Clutch Packs

SKU#	Product Description	Plate Load	Disc Springs	Disc Facing	Max. Torq.	Center Plate	Flywhl Dia.	Front Disc Flywhl Side	Rear Disc Press Plate Side	Pic. #
N10839174	New Two Plate, 2.0"-10 Spline, Angle Spring	4000	10	4 Pad – CB	1650	PL1632	8.5"	N128257	N128258	6
N10839174C	New Two Plate, 2.0"-10 Spline, Angle Spring	4000	10	4 Pad – Carbotic*	1650	PL1632	8.5"	N128257C	N128258C	6
N10839178	New Two Plate, 2.0"-10 Spline, Angle Spring	4000	10	Organic	1450	PL1631	8.5"	N128445	N128446	2
N10839181	New Two Plate, 2.0"-10 Spline, Angle Spring	4000	8	4 Pad – CB	1400	PL1632	7"	N128215	N128216	3
N10839181C	New Two Plate, 2.0"-10 Spline, Angle Spring	4000	8	4 Pad – Carbotic*	1400	PL1632	7"	N128215C	N128216C	3
N10839182	New Two Plate, 2.0"-10 Spline, Angle Spring	4000	8	Organic	1400	PL1631	7"	N127817	N127818	1
N10839193H	New Two Plate, 2.0"-10 Spline, Angle Spring	4000	10	6 Pad – CB	1860	PL1632	8.5"	N128539	N128540	9
N10839193HC	New Two Plate, 2.0"-10 Spline, Angle Spring	4000	10	6 Pad – Carbotic*	1860	PL1632	8.5"	N128539C	N128540C	9
N10892520CTM	New Two Plate, 2.0"-10 Spline, Angle Spring – TORQUEMONSTER	4000	7 NVL	6 Pad – Carbotic*	1860	PL1632	10"	N128708CTM	N128708CTM	10
N10892520TM	New Two Plate, 2.0"-10 Spline, Angle Spring – TORQUEMONSTER	4000	7 NVL	6 Pad – CB	1860	PL1632	10"	N128708TM	N128708TM	10
N10892525CTM	New Two Plate, 2.0"-10 Spline, Angle Spring – TORQUEMONSTER	4000	7 NVL	6 Pad – Carbotic*	2050	PL1632	10"	N128709CTM	N128709CTM	10
N10892525HCTM	New Two Plate, 2.0"-10 Spline, Angle Spring – TORQUEMONSTER	4000	7 NVL	6 Pad – Carbotic*	2250	PL1632	10"	N128709HCTM	N128709HCTM	10
N10892525HTM	New Two Plate, 2.0"-10 Spline, Angle Spring – TORQUEMONSTER	4000	7 NVL	6 Pad – CB	2250	PL1632	10"	N128709HTM	N128709HTM	10
N10892525TM	New Two Plate, 2.0"-10 Spline, Angle Spring – TORQUEMONSTER	4000	7 NVL	6 Pad – CB	2050	PL1632	10"	N128709TM	N128709TM	10
N10892530CTM	New Two Plate, 2.0"-10 Spline, Angle Spring – TORQUEMONSTER	4000	7 PDHT	6 Pad – Carbotic*	1860	PL1632	10"	N128716CTM	N128716CTM	11
N10892530TM	New Two Plate, 2.0"-10 Spline, Angle Spring – TORQUEMONSTER	4000	7 PDHT	6 Pad – CB	1860	PL1632	10"	N128716TM	N128716TM	11

15-1/2" EZ N LITE® Clutch Packs

08-CLUTCHES

N10892535CTM	New Two Plate, 2.0"-10 Spline, Angle Spring – TORQUEMONSTER	4000	7 PDHT	6 Pad – Carbolic*	2050	PL1632	10"	N128717CTM	N128717CTM	11
N10892535HCTM	New Two Plate, 2.0"-10 Spline, Angle Spring – TORQUEMONSTER	4000	7 PDHT	6 Pad – Carbolic*	2250	PL1632	10"	N128717HCTM	N128717HCTM	11
N10892535HTM	New Two Plate, 2.0"-10 Spline, Angle Spring – TORQUEMONSTER	4000	7 PDHT	6 Pad – CB	2250	PL1632	10"	N128717HTM	N128717HTM	11
N10892535TM	New Two Plate, 2.0"-10 Spline, Angle Spring – TORQUEMONSTER	4000	7 PDHT	6 Pad – CB	2050	PL1632	10"	N128717TM	N128717TM	11
N10892582	New Two Plate, 2.0"-10 Spline, Angle Spring	4000	7	4 Pad – CB	1700	PL1632	10"	N128462	N128462	4
N10892582C	New Two Plate, 2.0"-10 Spline, Angle Spring	4000	7	4 Pad – Carbolic*	1700	PL1632	10"	N128462C	N128462C	4
N10892582H	New Two Plate, 2.0"-10 Spline, Angle Spring	4000	7	6 Pad – CB	1700	PL1632	10"	N129462	N129462	8
N10892582HC	New Two Plate, 2.0"-10 Spline, Angle Spring	4000	7	6 Pad – Carbolic*	1700	PL1632	10"	N129462C	N129462C	8
N10893551	New Two Plate, 2.0"-10 Spline, Angle Spring	4000	9	4 Pad – CB	1760	PL1632	10"	N128362	N128363	5
N10893551C	New Two Plate, 2.0"-10 Spline, Angle Spring	4000	9	4 Pad – Carbolic*	1760	PL1632	10"	N128362C	N128363C	5
N10893551H	New Two Plate, 2.0"-10 Spline, Angle Spring	4000	9	6 Pad – CB	1760	PL1632	10"	N128537	N128538	8
N10893551HC	New Two Plate, 2.0"-10 Spline, Angle Spring	4000	9	6 Pad – Carbolic*	1760	PL1632	10"	N128537C	N128538C	8
N10893592HTM	New Two Plate, 2.0"-10 Spline, Angle Spring – TORQUEMONSTER	4000	9	6 Pad – CB	2250	PL1632	10"	CD-128570H	CD-128571H	-

Pull Type, Two Plate

Flat Flywheel, 1.75"-10/2.0"-10 Spline

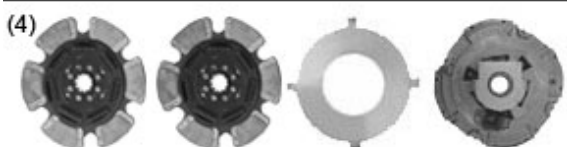
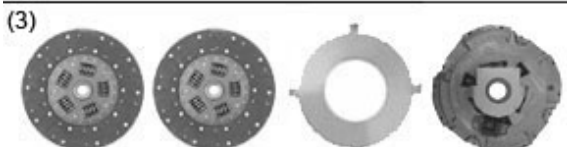
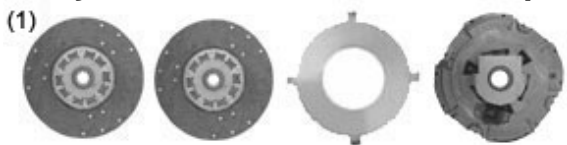

Features:

- Kevlar® (Dupont Corporation)
- Carbotic® (Wellman Friction Products)
- Easy-Pedal™ designated by EZ in Part Number

Specifications:

Cover Type Cast

Notes:

- 1) Rigid discs not recommended.
- 2) Typical application could vary depending upon vehicle.
- 3) Remanufactured Clutch Packs contain remanufactured cover assembly, new disc assemblies and resurfaced intermediate plate.

SKU#	Product Description	Maximum Torque Pounds-Feet (Pack)	Disc Springs	Disc Type	Approx. Weight	Typical Application	Required Flywheel Bore Diameter	Pic. #	Core Group
RC018CX	Standard Reman. Pull Type, Two Plate, Flat Flywheel, 2.0"-10 Spline	-	10 Springs	Damp Carbotic	143 lbs.	Cat 3406B/E DDA 60 Series Early Mack	8.5"	2	MU1502
RC018DOX	Standard Reman. Pull Type, Two Plate, Flat Flywheel, 2.0"-10 Spline	-	10 Springs	Damp Organic	140 lbs.	Cat 3406B/E DDA 60 Series Early Mack	8.5"	1	MU1502
RC018EZCX	Standard Reman. Pull Type, Two Plate, Flat Flywheel, 2.0"-10 Spline	1650	10 Springs	Damp Carbotic	140 lbs.	Cat 3406B/E DDA 60 Series Early Mack	8.5"	2	MU1505
RC018EZDOX	Standard Reman. Pull Type, Two Plate, Flat Flywheel, 2.0"-10 Spline	1200	10 Springs	Damp Organic	138 lbs.	Cat 3406B/E DDA 60 Series Early Mack	8.5"	1	MU1505
RC018EZHTX	Heavy Duty Reman. Pull Type, Two Plate, Flat Flywheel, 2.0"-10 Spline	1860	10 Springs	Damp Ceramic 6 Button	147 lbs.	Cat 3406B/E DDA 60 Series Early Mack	8.5"	2	MU1505
RC018EZKX	Standard Reman. Pull Type, Two Plate, Flat Flywheel, 2.0"-10 Spline	-	10 Springs	Damp Kevlar	140 lbs.	Cat 3406B/E DDA 60 Series Early Mack	8.5"	2	MU1505
RC018EZX	Standard Reman. Pull Type, Two Plate, Flat Flywheel,	1650	10 Springs	Damp Ceramic	143 lbs.	Cat 3406B/E DDA 60 Series Early Mack	8.5"	2	MU1505

15-1/2" Spicer Type Clutch Packs – Standard

08-CLUTCHES

	2.0"-10 Spline								
RC018KX	Standard Reman. Pull Type, Two Plate, Flat Flywheel, 2.0"-10 Spline	-	10 Springs	Damp Kevlar	143 lbs.	Cat 3406B/E DDA 60 Series Early Mack	8.5"	2	MU1502
RC018X	Standard Reman. Pull Type, Two Plate, Flat Flywheel, 2.0"-10 Spline	1650	10 Springs	Damp Ceramic	140 lbs.	Cat 3406B/E DDA 60 Series Early Mack	8.5"	2	MU1502
RC476DCX	Standard Reman. Pull Type, Two Plate, Flat Flywheel, 1.75"-10 Spline	1450	-	Damp Ceramic	138 lbs.	Various	7"	2	MU1502
RC476DOX	Standard Reman. Pull Type, Two Plate, Flat Flywheel, 1.75"-10 Spline	1200	-	Damp Organic	138 lbs.	Various	7"	1	MU1502
RC476ROX	Standard Reman. Pull Type, Two Plate, Flat Flywheel, 1.75"-10 Spline	1000	-	Rigid Organic	135 lbs.	Various	7"	3	MU1502
RC597CX	Standard Reman. Pull Type, Two Plate, Flat Flywheel, 2.0"-10 Spline	1450	-	Damp Carbotic	139 lbs.	Various	7"	2	MU1502
RC597DCX	Standard Reman. Pull Type, Two Plate, Flat Flywheel, 2.0"-10 Spline	1450	-	Damp Ceramic (Lipe Style Discs)	137 lbs.	Various	7"	2	MU1502
RC597DOX	Standard Reman. Pull Type, Two Plate, Flat Flywheel, 2.0"-10 Spline	1200	-	Damp Organic	139 lbs.	Various	7"	1	MU1502
RC597EZCX	Standard Reman. Pull Type, Two Plate, Flat Flywheel, 2.0"-10 Spline	1450	-	Damp Carbotic	141 lbs.	Various	7"	2	MU1505
RC597EZDCX	Standard Reman. Pull Type, Two Plate, Flat Flywheel, 2.0"-10 Spline	1450	-	Damp Ceramic (Lipe Style Discs)	144 lbs.	Various	7"	2	MU1505
RC597EZDOX	Standard Reman. Pull Type, Two Plate, Flat Flywheel, 2.0"-10 Spline	1200	-	Damp Organic	141 lbs.	Various	7"	1	MU1505
RC597EZKX	Standard Reman. Pull Type, Two Plate, Flat Flywheel, 2.0"-10 Spline	-	-	Damp Kevlar	135 lbs.	Various	7"	2	MU1505
RC597ROX	Standard Reman. Pull Type, Two Plate, Flat Flywheel, 2.0"-10 Spline	1000	-	Rigid Organic	134 lbs.	Various	7"	3	MU1502
RC698CX	Standard Reman. Pull Type, Two Plate, Flat Flywheel, 2.0"-10 Spline	-	9 Springs	Damp Carbotic	144 lbs.	Late Mack E6/E7	10"	2	MU1502
RC698EZCX	Standard Reman. Pull Type, Two Plate, Flat Flywheel, 2.0"-10 Spline	1650	9 Springs	Damp Carbotic	147 lbs.	Late Mack E6/E7	10"	2	MU1505

08-CLUTCHES

15-1/2" Spicer Type Clutch Packs – Standard

RC698EZHTX	Heavy Duty Reman. Pull Type, Two Plate, Flat Flywheel, 2.0"-10 Spline	1860	9 Springs	Damp Ceramic 6 Button	146 lbs.	Late Mack E6/E7	10"	2	MU1505
RC698EZKX	Standard Reman. Pull Type, Two Plate, Flat Flywheel, 2.0"-10 Spline	-	9 Springs	Damp Kevlar	144 lbs.	Late Mack E6/E7	10"	2	MU1505
RC698EZ	Standard Reman. Pull Type, Two Plate, Flat Flywheel, 2.0"-10 Spline	1650	9 Springs	Damp Ceramic	146 lbs.	Late Mack E6/E7	10"	2	MU1505
RC698X	Standard Reman. Pull Type, Two Plate, Flat Flywheel, 2.0"-10 Spline	1650	9 Springs	Damp Ceramic	144 lbs.	Late Mack E6/E7	10"	2	MU1502
RC700EZCX	Standard Reman. Pull Type, Two Plate, Flat Flywheel, 2.0"-10 Spline	1650	7 Springs	Damp Carbotic	146 lbs.	Cummins N-14	10"	2	MU1505
RC700EZHTX	Standard Reman. Pull Type, Two Plate, Flat Flywheel, 2.0"-10 Spline	1700	7 Springs	Damp Ceramic 6 Button	146 lbs.	Cummins N-14	10"	2	MU1505
RC700EZKX	Standard Reman. Pull Type, Two Plate, Flat Flywheel, 2.0"-10 Spline	-	7 Springs	Damp Kevlar	142 lbs.	Cummins N-14	10"	2	MU1505
RC700EZ	Standard Reman. Pull Type, Two Plate, Flat Flywheel, 2.0"-10 Spline	1650	7 Springs	Damp Ceramic	142 lbs.	Cummins N-14	10"	2	MU1505
RC700X	Standard Reman. Pull Type, Two Plate, Flat Flywheel, 2.0"-10 Spline	1650	7 Springs	Damp Ceramic	143 lbs.	Cummins N-14	10"	2	MU1502
RC892520EZ	TORQUEMONSTER Reman. Two Plate, 2.0"-10 Spline	1860	7NVL	6 Pad - CB	-	-	10"	4	MU1505
RC892525EZ	TORQUEMONSTER Reman. Two Plate, 2.0"-10 Spline	2050	7NVL	6 Pad - CB	-	-	10"	4	MU1505
RC892525HEZ	TORQUEMONSTER Reman. Two Plate, 2.0"-10 Spline	2250	7NVL	6 Pad - CB	-	-	10"	4	MU1505
RC892530EZ	TORQUEMONSTER Reman. Two Plate, 2.0"-10 Spline	1860	7 PDHT	6 Pad - CB	-	-	10"	4	MU1505
RC892535EZ	TORQUEMONSTER Reman. Two Plate, 2.0"-10 Spline	2050	7 PDHT	6 Pad - CB	-	-	10"	4	MU1505
RC892535HEZ	TORQUEMONSTER Reman. Two Plate, 2.0"-10 Spline	2250	7 PDHT	6 Pad - CB	-	-	10"	4	MU1505
RC893592HEZ	Heavy Duty Reman. Pull Type, Two Plate, Flat Flywheel, 2.0"-10 Spline	2250	9 Springs	Damp Ceramic 6 Button	146 lbs.	Late Mack E6/E7	10"	2	MU1505

Pull Type, Two Plate

Flat Flywheel, 1.75"-10/2.0"-10 Spline

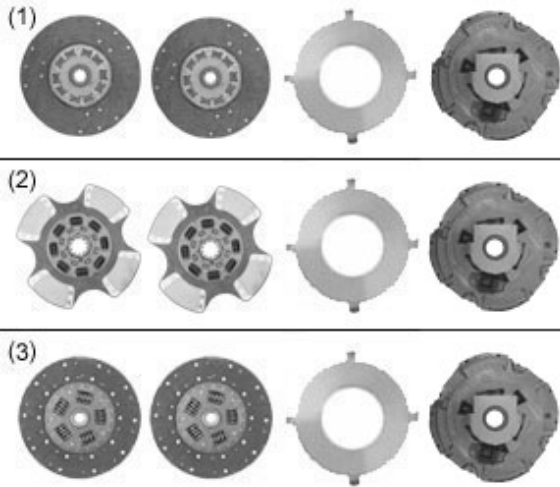

Features:

- Kevlar® (Dupont Corporation)
- Carbotic® (Wellman Friction Products)
- Easy-Pedal™ designated by EZ in Part Number

Specifications:

Cover Type Cast

Notes:

- 1) Rigid discs not recommended.
- 2) Typical application could vary depending upon vehicle.
- 3) Remanufactured Clutch Packs contain remanufactured cover assembly, new disc assemblies and new intermediate plate.

SKU#	Product Description	Max. Torque	Disc Type	Approx. Weight	Typical Application	Required Flywheel Bore Diameter	Pic. #	Core Group
MU018CX	Premium Reman. Pull Type, Two Plate, Flat Flywheel, 2.0"-10 Spline	1650	10 Spring Carbotic	140 lbs.	Cat 3406B/E DDA 60 Series Early Mack	8.5"	2	MU1502
MU018EZCX	Premium Reman. Pull Type, Two Plate, Flat Flywheel, 2.0"-10 Spline	1650	10 Spring Carbotic	140 lbs.	Cat 3406B/E DDA 60 Series Early Mack	8.5"	2	MU1505
MU018EZHTX	Heavy Duty Reman. Pull Type, Two Plate, Flat Flywheel, 2.0"-10 Spline, High Torque	1860	10 Spring Ceramic 6 Button	147 lbs.	Cat 3406B/E DDA 60 Series Early Mack	8.5"	2	MU1505
MU018EZKX	Premium Reman. Pull Type, Two Plate, Flat Flywheel, 2.0"-10 Spline	-	10 Spring Kevlar	140 lbs.	Cat 3406B/E DDA 60 Series Early Mack	8.5"	2	MU1505
MU018EZX	Premium Reman. Pull Type, Two Plate, Flat Flywheel, 2.0"-10 Spline	1650	10 Spring Ceramic	144 lbs.	Cat 3406B/E DDA 60 Series Early Mack	8.5"	2	MU1505
MU018KX	Premium Reman. Pull Type, Two Plate, Flat Flywheel, 2.0"-10 Spline	-	10 Spring Kevlar	140 lbs.	Cat 3406B/E DDA 60 Series Early Mack	8.5"	2	MU1502
MU018X	Premium Reman. Pull Type, Two Plate, Flat Flywheel, 2.0"-10 Spline	1650	10 Spring Ceramic	144 lbs.	Cat 3406B/E DDA 60 Series Early Mack	8.5"	2	MU1502
MU476DCX	Premium Reman. Pull Type, Two Plate, Flat Flywheel, 1.75"-10 Spline	1450	Damp Ceramic	137 lbs.	Various	7"	2	MU1502
MU476DOX		1200		139 lbs.	Various	7"	1	MU1502

08-CLUTCHES

15-1/2" Spicer Type Clutch Packs – Premium

	Premium Reman. Pull Type, Two Plate, Flat Flywheel, 1.75"-10 Spline		Damp Organic					
MU476ROX	Premium Reman. Pull Type, Two Plate, Flat Flywheel, 1.75"-10 Spline	1000	Rigid Organic	137 lbs.	Various	7"	3	MU1502
MU597CX	Premium Reman. Pull Type, Two Plate, Flat Flywheel, 2.0"-10 Spline	1450	Damp Carbotic	137 lbs.	Various	7"	2	MU1502
MU597DCX	Premium Reman. Pull Type, Two Plate, Flat Flywheel, 2.0"-10 Spline	1450	Damp Ceramic (Lipe Style Discs)	148 lbs.	Various	7"	2	MU1502
MU597DOX	Premium Reman. Pull Type, Two Plate, Flat Flywheel, 2.0"-10 Spline	1200	Damp Organic	139 lbs.	Various	7"	1	MU1502
MU597EZCX	Premium Reman. Pull Type, Two Plate, Flat Flywheel, 2.0"-10 Spline	1450	Damp Carbotic	144 lbs.	Various	7"	2	MU1505
MU597EZDCX	Premium Reman. Pull Type, Two Plate, Flat Flywheel, 2.0"-10 Spline	1450	Damp Ceramic (Lipe Style Discs)	143 lbs.	Various	7"	2	MU1505
MU597EZDOX	Premium Reman. Pull Type, Two Plate, Flat Flywheel, 2.0"-10 Spline	1200	Damp Organic	141 lbs.	Various	7"	1	MU1505
MU597EZKX	Premium Reman. Pull Type, Two Plate, Flat Flywheel, 2.0"-10 Spline	-	Damp Kevlar	144 lbs.	Various	7"	2	MU1505
MU597KX	Premium Reman. Pull Type, Two Plate, Flat Flywheel, 2.0"-10 Spline	-	Damp Kevlar	137 lbs.	Various	7"	2	MU1502
MU597ROX	Premium Reman. Pull Type, Two Plate, Flat Flywheel, 2.0"-10 Spline	1000	Rigid Organic	137 lbs.	Various	7"	3	MU1502
MU597SSCX	Premium Reman. Pull Type, Two Plate, Flat Flywheel, 2.0"-10 Spline	1150	Rigid Ceramic Spline Saver	138 lbs.	Various	7"	not shown	MU1502
MU597SSOX	Premium Reman. Pull Type, Two Plate, Flat Flywheel, 2.0"-10 Spline	1000	Rigid Organic Spline Saver	87 lbs.	Various	7"	not shown	MU1502
MU698CX	Premium Reman. Pull Type, Two Plate, Flat Flywheel, 2.0"-10 Spline	1650	9 Spring Carbotic	146 lbs.	Late Mack E6/E7	10"	2	MU1502
MU698EZCX	Premium Reman. Pull Type, Two Plate, Flat Flywheel, 2.0"-10 Spline	1650	9 Spring Carbotic	146 lbs.	Late Mack E6/E7	10"	2	MU1505

15-1/2" Spicer Type Clutch Packs – Premium

08-CLUTCHES

MU698EZHTX	Heavy Duty Reman. Pull Type, Two Plate, Flat Flywheel, 2.0"-10 Spline, High Torque	1860	9 Spring Ceramic 6 Button	147 lbs.	Late Mack E6/E7	10"	2	MU1505
MU698EZKX	Premium Reman. Pull Type, Two Plate, Flat Flywheel, 2.0"-10 Spline	-	9 Spring Kevlar	148 lbs.	Late Mack E6/E7	10"	2	MU1505
MU698EZ	Premium Reman. Pull Type, Two Plate, Flat Flywheel, 2.0"-10 Spline	1650	9 Spring Ceramic	147 lbs.	Late Mack E6/E7	10"	2	MU1505
MU698X	Premium Reman. Pull Type, Two Plate, Flat Flywheel, 2.0"-10 Spline	1650	9 Spring Ceramic	147 lbs.	Late Mack E6/E7	10"	2	MU1505
MU700CX	Premium Reman. Pull Type, Two Plate, Flat Flywheel, 2.0"-10 Spline	1650	7 Spring Carbotic	147 lbs.	Cummins N-14	10"	2	MU1502
MU700EZCX	Premium Reman. Pull Type, Two Plate, Flat Flywheel, 2.0"-10 Spline	1650	7 Spring Carbotic	147 lbs.	Cummins N-14	10"	2	MU1505
MU700EZHTX	Heavy Duty Reman. Pull Type, Two Plate, Flat Flywheel, 2.0"-10 Spline, High Torque	2050	7 Spring Ceramic 6 Button	147 lbs.	Cummins N-14	10"	2	MU1505
MU700EZKX	Premium Reman. Pull Type, Two Plate, Flat Flywheel, 2.0"-10 Spline	-	7 Spring Kevlar	147 lbs.	Cummins N-14	10"	2	MU1505
MU700EZ	Premium Reman. Pull Type, Two Plate, Flat Flywheel, 2.0"-10 Spline	1650	7 Spring Ceramic	147 lbs.	Cummins N-14	10"	2	MU1505
MU700X	Premium Reman. Pull Type, Two Plate, Flat Flywheel, 2.0"-10 Spline	-	7 Spring Ceramic	147 lbs.	Cummins N-14	10"	2	MU1502

15-1/2" Standard Clutch Pack – Spicer Type

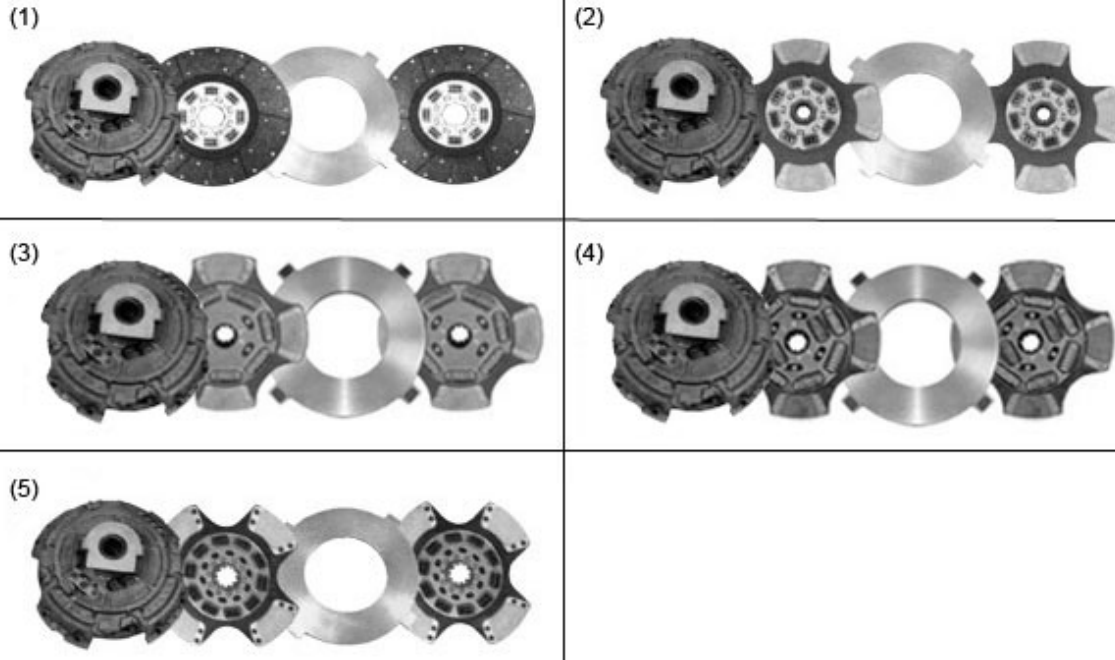

Note: *Carbotic® (Wellman Friction Products)

SKU#	Product Description	Plate Load	Disc Springs	Disc Facing	Max. Torq.	Center Plate	Flywhl Dia.	Front Disc Flywhl Side	Rear Disc Press Plate Side	Pic. #
N10709174	New Two Plate, 2.0"-10 Spline	3600	10	4 Pad – CB	1650	PL1632	8.5"	N128257	N128258	5
N10709181	New Two Plate, 2.0"-10 Spline	3600	8	4 Pad – CB	1400	PL1632	7"	N128215	N128216	2
N10709181C	New Two Plate, 2.0"-10 Spline	3600	8	4 Pad – Carbotic*	1400	PL1632	7"	N128215C	N128216C	2
N10709182	New Two Plate, 2.0"-10 Spline	3600	8	Organic	1400	PL1631	7"	N127817	N127818	1
N10709193H	New Two Plate, 2.0"-10 Spline	3600	10	6 Pad – CB	1860	PL1632	8.5"	N128539	N128540	-
N10739174C	New Two Plate, 2.0"-10 Spline	3600	10	4 Pad – Carbotic*	1650	PL1632	8.5"	N128257C	N128258C	5
N10739178	New Two Plate, 2.0"-10 Spline	3600	10	Organic	1450	PL1631	8.5"	N128445	N128446	-
N10792582	New Two Plate, 2.0"-10 Spline	3600	7	4 Pad – CB	1700	PL1632	10"	N128462	N128462	3
N10792582C	New Two Plate, 2.0"-10 Spline	3600	7	4 Pad – Carbotic*	1700	PL1632	10"	N128462C	N128462C	3
N10793551	New Two Plate, 2.0"-10 Spline	3600	9	4 Pad – CB	1760	PL1632	10"	N128362	N128363	4
N10793551C	New Two Plate, 2.0"-10 Spline	3600	9	4 Pad – Carbotic*	1760	PL1632	10"	N128362C	N128363C	4

Pull Type, Two Plate

Flat Flywheel, 2.0"-10 Spline



Features:

- Quality remanufactured cover
- New discs tested to five million cycles for maximum durability

Specifications:

Application Various

SKU#	Product Description	Meritor Part Number	Max. Torque	Plate Load	Disc Type	Required Flywheel Bore Diameter	Approx. Weight	Core Group
RC141101X	Reman. 14" Pull Type, Two Plate, Flat Flywheel, 2.0"-10 Spline	HC14C2200NN32	1400	3200	8 Spring Damp Ceramic	7"	105 lbs.	R1401
RC151406X	Reman. 15-1/2" Pull Type, Two Plate, Flat Flywheel, 2.0"-10 Spline	HC15C2200TN36	1730	3600	8 Spring Damp Ceramic	8.5"	140 lbs.	R1501
RC152705X	Reman. 15-1/2" Pull Type, Two Plate, Flat Flywheel, 2.0"-10 Spline	HC15L2200NW36	1730	3600	7 Spring Damp Ceramic	10"	142 lbs.	R1501
RC152725X	Reman. 15-1/2" Pull Type, Two Plate, Flat Flywheel, 2.0"-10 Spline	HC15L2200ZN36	1730	3600	7 Spring Damp Ceramic	10"	142 lbs.	R1501

Cover Assemblies

for 11" Clutch

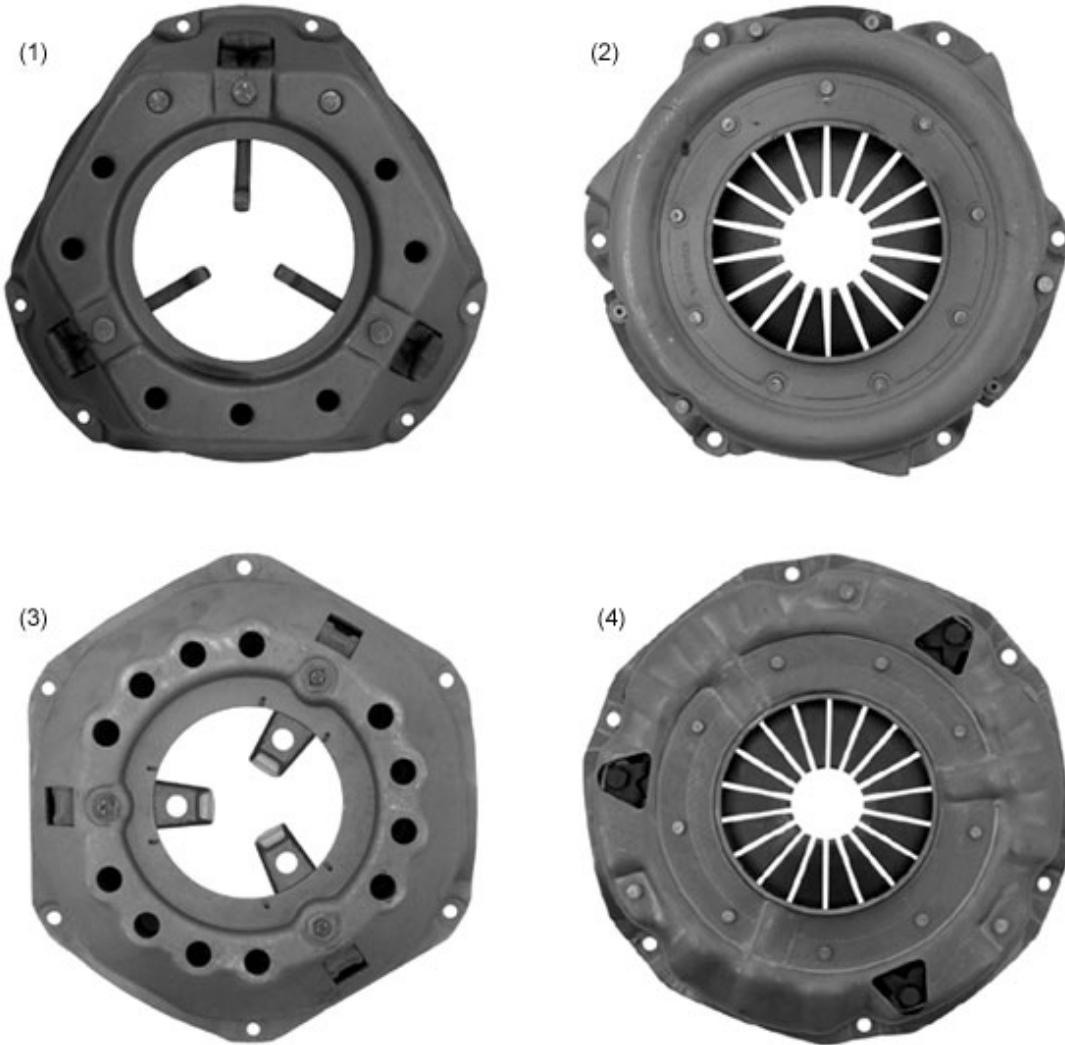

SKU#	Product Description	Pic. #	Core Group
RCA0033X	Remanufactured 11" LUK Cover Assembly	2	CA1101
RCA0049X	Remanufactured 11" LUK Cover Assembly	2	CA1101
RCA0465X	Remanufactured 11" Long Cover Assembly	1	CA1101
RCA1009X	Remanufactured 11" Borg & Beck – LUK Cover Assembly	2	CA1101
RCA1857X	Remanufactured 11" Borg & Beck Cover Assembly	3	CA1101
RCA5473X	Remanufactured 11" GMC Cover Assembly	4	CA1101
RCA5505X	Remanufactured 11" GMC Cover Assembly	4	CA1101
RCA5551X	Remanufactured 11" GMC Cover Assembly	4	CA1101

Cover Assemblies

for 12" Clutch

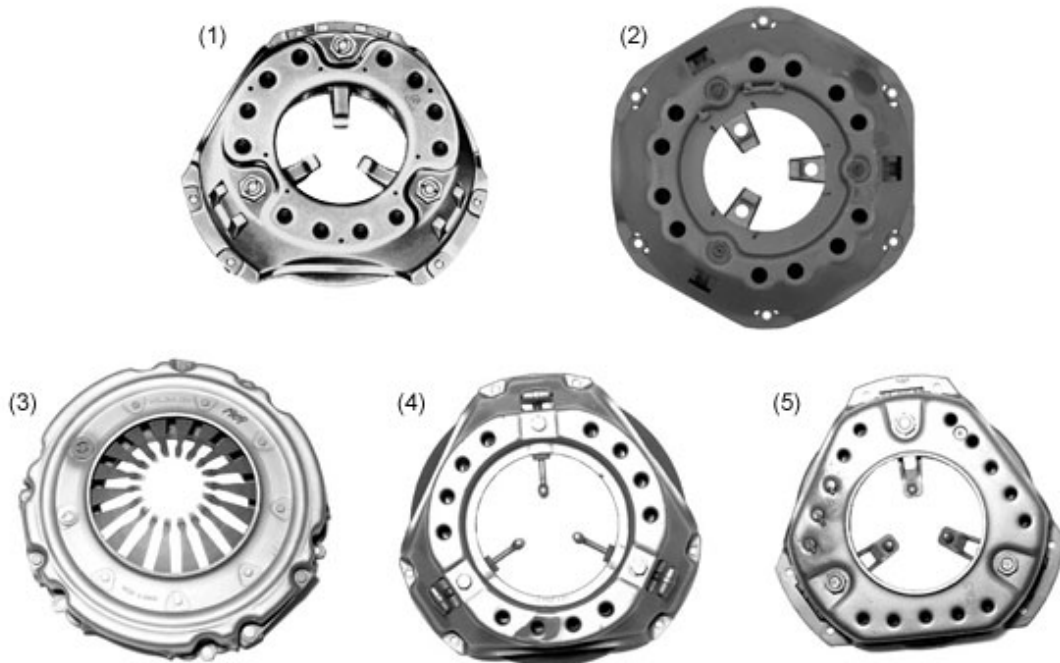

SKU#	Product Description	Pic. #	Core Group
RCA0263X	Remanufactured 12" Long Cover Assembly	4	CA1201
RCA0628X	Remanufactured 12" Lipe Cover Assembly	1	LP1201
RCA1865X	Remanufactured 12" Borg & Beck Cover Assembly	2	CA1201
RCA1909X	Remanufactured 12" Borg & Beck – LUK Cover Assembly	3	CA1201
RCA5429X	Remanufactured 12" Rockford Cover Assembly	5	CA1201

Cover Assemblies

for 13" Clutch

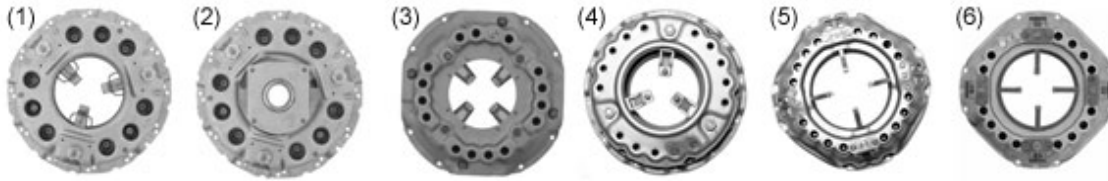

SKU#	Product Description	Picture Number	Core Group
RC3301931X	Remanufactured 13" Lipe	1	LP3301
RC3301933X	Remanufactured 13" Lipe	1	LP3301
RC3301935X	Remanufactured 13" Lipe	1	LP3301
RC3301937X	Remanufactured 13" Lipe	1	LP3301
RC3301938X	Remanufactured 13" Lipe	1	LP3301
RC3301940X	Remanufactured 13" Lipe	1	LP3301
RC3301941X	Remanufactured 13" Lipe	1	LP3301
RC3301989X	Remanufactured 13" Lipe	1	LP3301
RC3302077X	Remanufactured 13" Lipe	1	LP3301
RCA0539X	Remanufactured 13" Long	5	CA1301
RCA1014X	Remanufactured 13" Long	6	MU1303
RCA1866X	Remanufactured 13" Borg & Beck	3	CA1301
RCA1882X	Remanufactured 13" Borg & Beck	3	CA1301
RCA5435X	Remanufactured 13" Rockford	4	CA1301

Cover Assemblies

for 14" Clutch

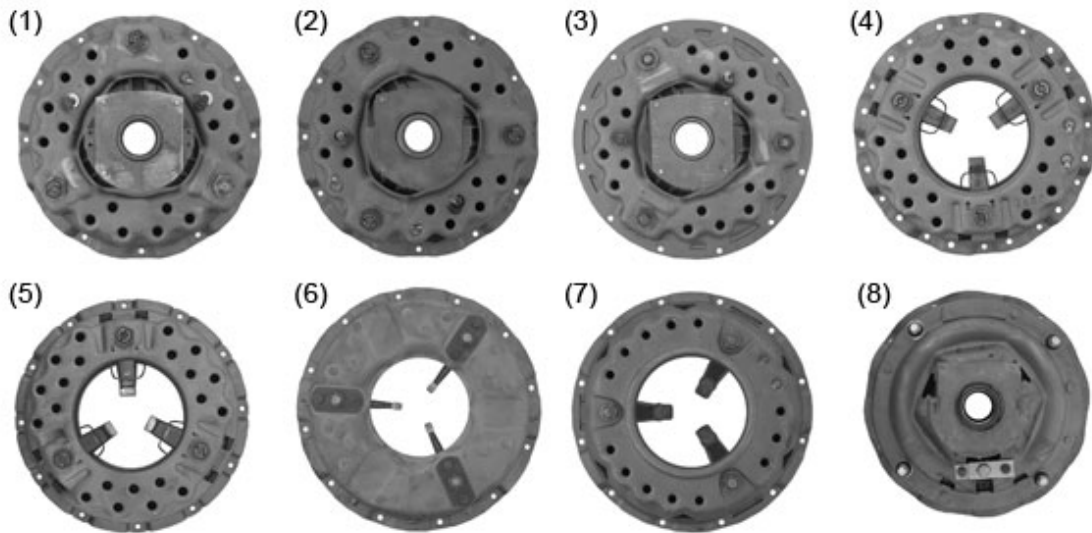

SKU#	Product Description	Picture Number	Core Group
CA044X	Remanufactured 14" Spicer	8	MU1404
RC141047X	Remanufactured 14" Lipe	4	LP1401
RC141072X	Remanufactured 14" Lipe	5	LP1401
RC141076X	Remanufactured 14" Lipe	4	LP1401
RC141086X	Remanufactured 14" Lipe	4	LP1401
RC141098X	Remanufactured 14" Lipe	4	LP1401
RC141113X	Remanufactured 14" Lipe	5	LP1401
RC141686X	Remanufactured 14" Lipe	4	LP1401
RC141707X	Remanufactured 14" Lipe	3	LP1402
RC141714X	Remanufactured 14" Lipe	2	LP1402
RC141767X	Remanufactured 14" Lipe	3	LP1402
RC141777X	Remanufactured 14" Lipe	3	LP1402
RC141778X	Remanufactured 14" Lipe	3	LP1402
RC141854X	Remanufactured 14" Lipe	1	LP1402
RCA0632X	Remanufactured 14" Long	6	CA1402
RCA5424X	Remanufactured 14" Rockford	7	CA1402

Disc Assemblies

for 11" Clutch

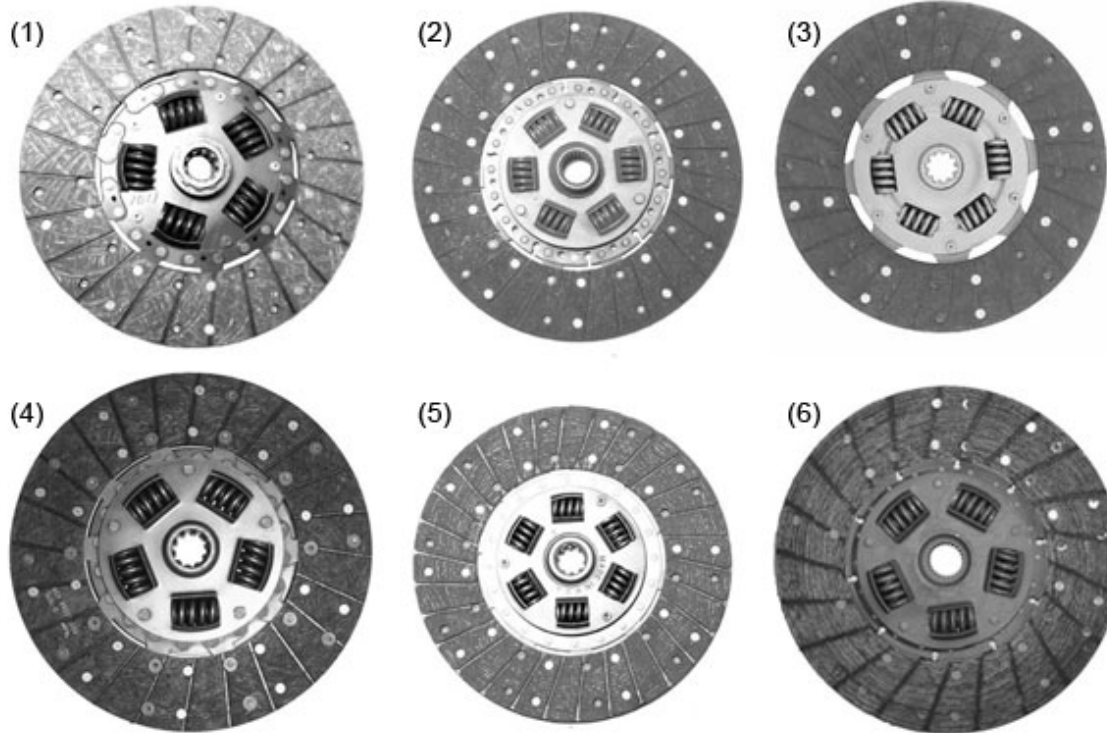

**Discs purchased separately are outright.
No core charge/return applicable.**

SKU#	Product Description	Pic. #
RCD0872RX	Remanufactured Disc Assembly for 11" Long Clutch	3
RCD1011RX	Remanufactured Disc Assembly for 11" GMC, LUK Clutch	1
RCD1023RX	Remanufactured Disc Assembly for 11" Borg & Beck, LUK Clutch	5
RCD3348RX	Remanufactured Disc Assembly for 11" GMC Clutch	4
RCD3735RX	Remanufactured Disc Assembly for 11" GMC Clutch	4
RCD4018RX	Remanufactured Disc Assembly for 11" Borg & Beck Clutch	2
RCD4148RX	Remanufactured Disc Assembly for 11" GMC Clutch	6

Disc Assemblies

for 12" Clutch

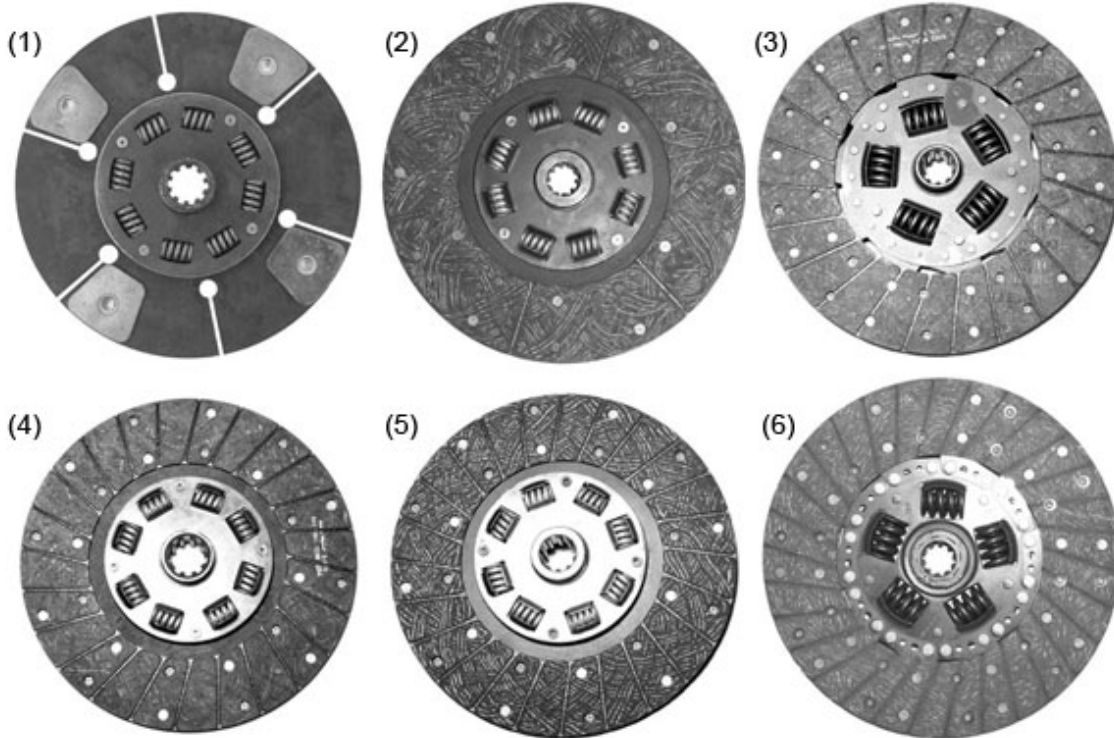

**Discs purchased separately are outright.
No core charge/return applicable.**

SKU#	Product Description	Pic. #
RCD0134RX	Remanufactured Disc Assembly for 12" Lipe Clutch	2
RCD0568RX	Remanufactured Disc Assembly for 12" Long Clutch	4
RCD1110RX	Remanufactured Disc Assembly for 12" Lipe Clutch	2
RCD1251RX	Remanufactured Disc Assembly for 12" Lipe Clutch	1
RCD3904RX	Remanufactured Disc Assembly for 12" Borg & Beck, Borg & Beck-LUK Clutch	3
RCD4195RX	Remanufactured Disc Assembly for 12" Borg & Beck-LUK Clutch	6
RCD5121RX	Remanufactured Disc Assembly for 12" Rockford Clutch	5

Disc Assemblies

for 13" Clutch

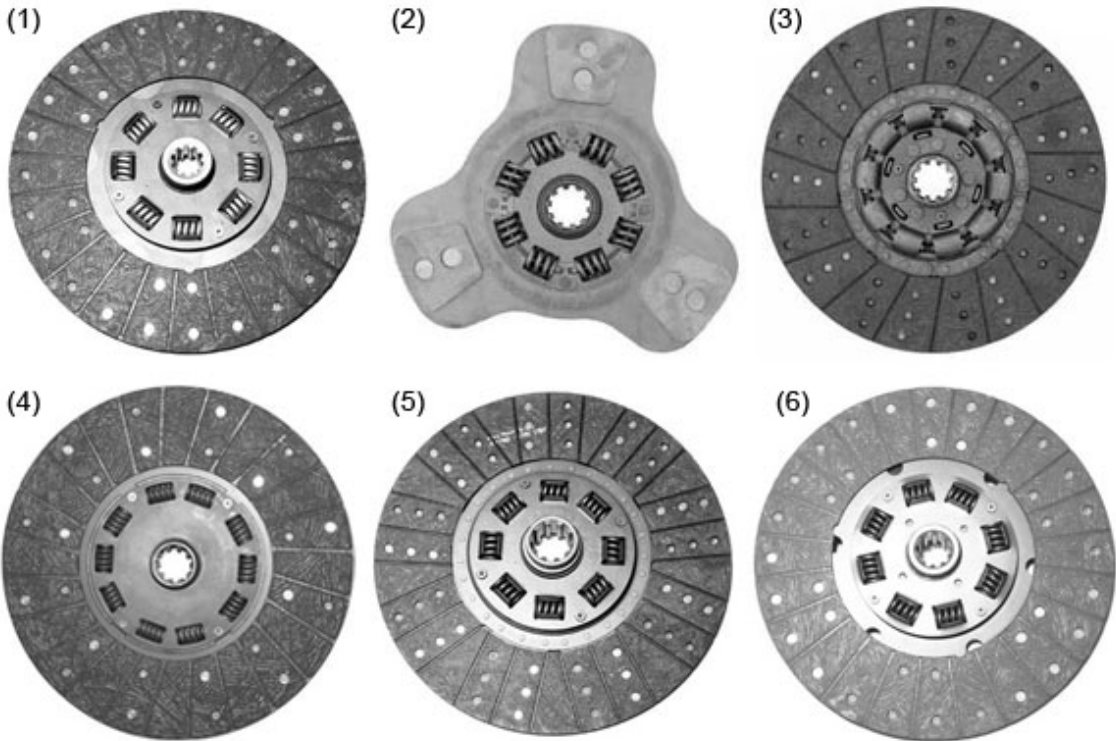

**Remanufactured Discs purchased separately are outright.
No core charge/return applicable.**

SKU#	Product Description	Picture Number
RCD0094RX	Remanufactured Disc Assembly for 13" Long Clutch	1
RCD0629RX	Remanufactured Disc Assembly for 13" Long Clutch	4
RCD2824RX	Remanufactured Disc Assembly for 13" Borg & Beck Clutch	5
RCD2942RX	Remanufactured Disc Assembly for 13" Borg & Beck Clutch	2
RCD4182RX	Remanufactured Disc Assembly for 13" Borg & Beck Clutch	2
RCD5123RX	Remanufactured Disc Assembly for 13" Rockford Clutch	3
RCD5210RX	Remanufactured Disc Assembly for 13" Rockford Clutch	6

Disc Assemblies

for 14" Clutch



8 Spring - Organic



RCD1001RX



RCD5139RX



8 Spring
3 Pad VTL - Ceramic



8 Spring
3 Pad - Ceramic



8 Spring
4 Pad - Ceramic



8 Spring
6 Pad - Ceramic

**Remanufactured Discs purchased separately are outright.
No core charge/return applicable.**

SKU#	Product Description	Disc Springs	Disc Facing	Side
N127261	New 14" x 1-3/4" Disc Assembly – Eaton Style	8	Organic	Flywheel
N127262	New 14" x 1-3/4" Disc Assembly – Eaton Style	8	Organic	Pressure Plate
N127273	New 14" x 2" Disc Assembly – Eaton Style	8	Organic	Flywheel
N127274	New 14" x 2" Disc Assembly – Eaton Style	8	Organic	Pressure Plate
N127404	New 14" x 1-3/4" Disc Assembly – Eaton Style	8	4 Pad – CB	Flywheel
N127405	New 14" x 1-3/4" Disc Assembly – Eaton Style	8	4 Pad – CB	Pressure Plate
N128101	New 14" x 2" Disc Assembly – Eaton Style	8	6 Pad – CB	Flywheel
N128102	New 14" x 2" Disc Assembly – Eaton Style	8	6 Pad – CB	Pressure Plate
N128229	New 14" x 2" Disc Assembly – Eaton Style	8	4 Pad – CB	Flywheel
N128229C	New 14" x 2" Disc Assembly – Eaton Style	8	4 Pad – Carbotic	Flywheel
N128230	New 14" x 2" Disc Assembly – Eaton Style	8	4 Pad – CB	Pressure Plate
N128230C	New 14" x 2" Disc Assembly – Eaton Style	8	4 Pad – Carbotic	Pressure Plate
N128231	New 14" x 2" Disc Assembly – Eaton Style	8	3 Pad – CB	Flywheel
N128232	New 14" x 2" Disc Assembly – Eaton Style	8	3 Pad – CB	Pressure Plate
N128238	New 14" x 2" Disc Assembly – Eaton Style	8	Organic	Flywheel
N128239	New 14" x 2" Disc Assembly – Eaton Style	8	Organic	Pressure Plate
N128275	New 14" x 1-3/4" Disc Assembly – Eaton Style	8	3 Pad – CB	Flywheel
N128276	New 14" x 1-3/4" Disc Assembly – Eaton Style	8	3 Pad – CB	Pressure Plate
N128521	New 14" x 2" Disc Assembly – Eaton Style	8	4 Pad – CB	Flywheel
N128521C	New 14" x 2" Disc Assembly – Eaton Style	8	4 Pad – Carbotic	Flywheel
N128522	New 14" x 2" Disc Assembly – Eaton Style	8	4 Pad – CB	Pressure Plate

08-CLUTCHES

Clutch Accessories

N128522C	New 14" x 2" Disc Assembly – Eaton Style	8	4 Pad – Carbotic	Pressure Plate
N128574	New 14" x 2" Disc Assembly – Eaton Style	8	6 Pad – CB	Flywheel
N128575	New 14" x 2" Disc Assembly – Eaton Style	8	6 Pad – CB	Pressure Plate
N128578	New 14" x 1-3/4" Disc Assembly – Eaton Style	8	3 Pad VTL – CB	Flywheel
N128579	New 14" x 1-3/4" Disc Assembly – Eaton Style	8	3 Pad VTL – CB	Pressure Plate
RCD1001RX	Remanufactured Disc Assembly for 14" Long Clutch	–	Organic	–
RCD5139RX	Remanufactured Disc Assembly for 14" Rockford Clutch	–	Organic	–

Disc Assemblies

for 15-1/2" Clutch

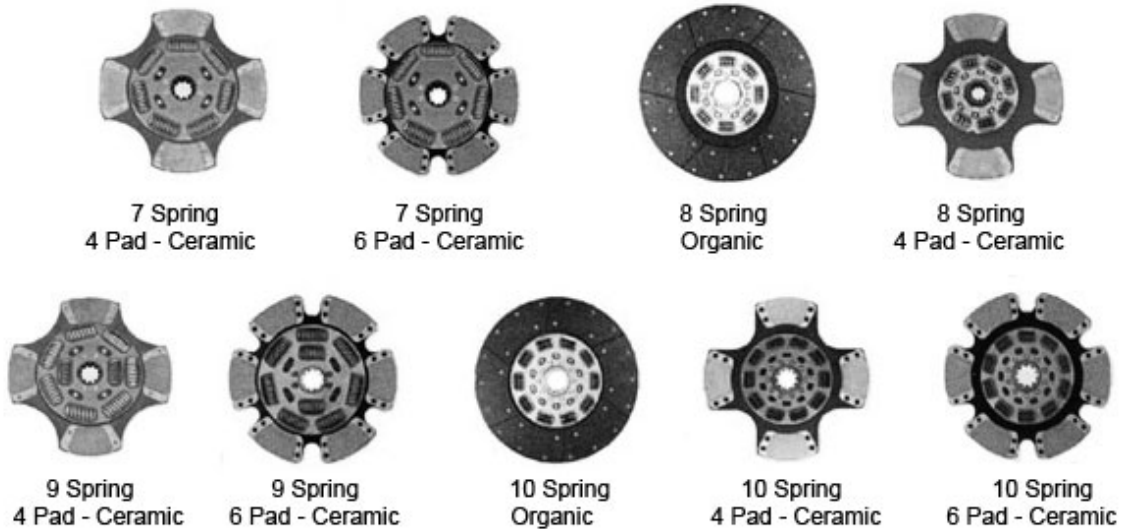

SKU#	Product Description	Disc Springs	Disc Facing	Side
N127817	New 15-1/2" x 2" Disc Assembly – Eaton Style	8	Organic	Flywheel
N127818	New 15-1/2" x 2" Disc Assembly – Eaton Style	8	Organic	Pressure Plate
N128215	New 15-1/2" x 2" Disc Assembly – Eaton Style	8	4 Pad – CB	Flywheel
N128215C	New 15-1/2" x 2" Disc Assembly – Eaton Style	8	4 Pad – Carbotic	Flywheel
N128216	New 15-1/2" x 2" Disc Assembly – Eaton Style	8	4 Pad – CB	Pressure Plate
N128216C	New 15-1/2" x 2" Disc Assembly – Eaton Style	8	4 Pad – Carbotic	Pressure Plate
N128257	New 15-1/2" x 2" Disc Assembly – Eaton Style	10	4 Pad – CB	Flywheel
N128257C	New 15-1/2" x 2" Disc Assembly – Eaton Style	10	4 Pad – Carbotic	Flywheel
N128258	New 15-1/2" x 2" Disc Assembly – Eaton Style	10	4 Pad – CB	Pressure Plate
N128258C	New 15-1/2" x 2" Disc Assembly – Eaton Style	10	4 Pad – Carbotic	Pressure Plate
N128362	New 15-1/2" x 2" Disc Assembly – Eaton Style	9	4 Pad – CB	Flywheel
N128362C	New 15-1/2" x 2" Disc Assembly – Eaton Style	9	4 Pad – Carbotic	Flywheel
N128363	New 15-1/2" x 2" Disc Assembly – Eaton Style	9	4 Pad – CB	Pressure Plate
N128363C	New 15-1/2" x 2" Disc Assembly – Eaton Style	9	4 Pad – Carbotic	Pressure Plate
N128445	New 15-1/2" x 2" Disc Assembly – Eaton Style	10	Organic	Flywheel
N128446	New 15-1/2" x 2" Disc Assembly – Eaton Style	10	Organic	Pressure Plate
N128462	New 15-1/2" x 2" Disc Assembly – Eaton Style	7	4 Pad – CB	–
N128462C	New 15-1/2" x 2" Disc Assembly – Eaton Style	7	4 Pad – Carbotic	–
N128537	New 15-1/2" x 2" Disc Assembly – Eaton Style	9	6 Pad – CB	Flywheel
N128537C	New 15-1/2" x 2" Disc Assembly – Eaton Style	9	6 Pad – Carbotic	Flywheel
N128538	New 15-1/2" x 2" Disc Assembly – Eaton Style	9	6 Pad – CB	Pressure Plate
N128538C	New 15-1/2" x 2" Disc Assembly – Eaton Style	9	6 Pad – Carbotic	Pressure Plate
N128539	New 15-1/2" x 2" Disc Assembly – Eaton Style	10	6 Pad – CB	Flywheel

08-CLUTCHES

Clutch Accessories

N128539C	New 15-1/2" x 2" Disc Assembly – Eaton Style	10	6 Pad – Carbotic	Flywheel
N128540	New 15-1/2" x 2" Disc Assembly – Eaton Style	10	6 Pad – CB	Pressure Plate
N128540C	New 15-1/2" x 2" Disc Assembly – Eaton Style	10	6 Pad – Carbotic	Pressure Plate
N128541	New 15-1/2" x 2" Disc Assembly – Eaton Style	7	6 Pad – CB	–
N128541C	New 15-1/2" x 2" Disc Assembly – Eaton Style	7	6 Pad – Carbotic	–
N128604	New 15-1/2" x 2" Disc Assembly – Eaton Style	7 4	6 Pad – CB	–
N128604C	New 15-1/2" x 2" Disc Assembly – Eaton Style	7 4	6 Pad – Carbotic	–

Intermediate Plates

For Spicer Clutch Pack



SKU#	Product Description	Application
CP044	Intermediate Plate 044ST	RC044STDCX, RC044STDOX

Clutch Brake Spacer

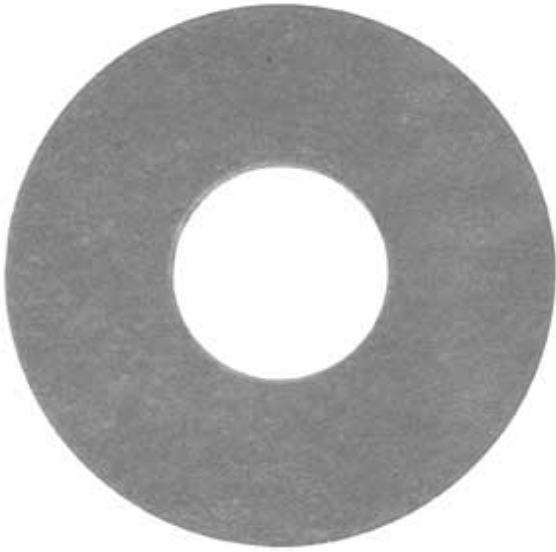

SKU#	Product Description	Outside Diameter	Spline Size
RC2504LK	Clutch Brake Spacer	4-1/8"	1-3/4"
RC2540K	Clutch Brake Washer	4-1/8"	2"

Hinge Clutch Brake Kits



SKU#	Product Description	Outside Diameter	Spline Size
BK312	Hinge Clutch Brake	4-1/8"	1-3/4"
BK313	Hinge Clutch Brake	4-1/8"	2"

Drive Pins



RC183145K



RC1923LK



RC2523XK

SKU#	Product Description	Standard Pack	Application
RC183145K	Clutch Drive Pin	8	Mack 15" (Threaded)
RC1923LK	Clutch Drive Pin	1	Lipe
RC2523XK	Clutch Drive Pin	6	Lipe & Spicer

Clutch Related Tools



SKU#	Product Description	Comments
RC3004K	Clutch Adjuster	-
RC5362K	Clutch Tool	1-3/8" - 10 Spline
RC5379K	Clutch Alignment Shaft	1-1/2" - 10 Spline
RC5380K	Clutch Alignment Shaft	1-3/4" - 10 Spline
RC5381K	Clutch Alignment Shaft	2" - 10 Spline
RC5409K	Clutch Tool	1-1/4" - 10 Spline
RC5410K	Clutch Alignment Shaft	1-3/4" - 10 Spline
TCT017	Drive Pin Alignment Gauge & Tool	Lipe Application Replaces T-10670A, TCT-1
TCT5044	Manual Adjuster with Lock for EZ™ Pedal and/or Self-Adjust Eaton-Style Cover	-

Installation Kits



N2468K Shown

SKU#	Product Description	Application
N2468K	New Clutch Installation Kit	RT Series
N3600K	Eaton K-3600 Series Clutch Installation Kit	Eaton FR Transmission Series

The clutch linkage is probably the most misunderstood component of the vehicle, and yet it is one of the simplest. Let us now look at what functions the linkage provides and how it relates to the pedal position.

There are four sections/zones to the clutch linkage. They are:

Zone (A) Clutch Pedal Free-Play. This free-play in the clutch linkage is actually clearance between the clutch release bearing and the release levers of the clutch cover (on a Push Type clutch). For a Pull Type clutch the clearance is between the yoke release cams and the release bearing housing. This zone should be approximately 1-3/4 in length. (Figures 1 and 2)

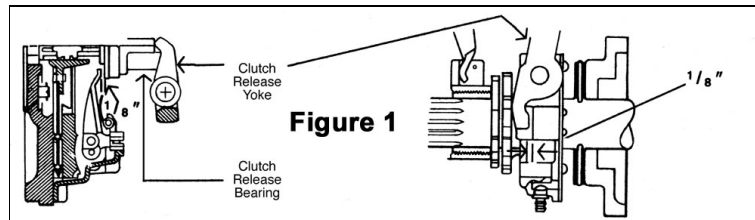

Zone (B) Engagement and Disengagement Zone. This section starts at the point where you will notice a decrease in engine R.P.M. without the vehicle moving to the point on the pedal where the clutch is completely engaged. This zone (pedal travel) should be approximately 2/3 of the total pedal travel. For example, if the total pedal travel (from the floor to pedal rest position) is 9, then the engage-disengage zone should be as close as possible to 6 for smooth engagement. (Figure 2)

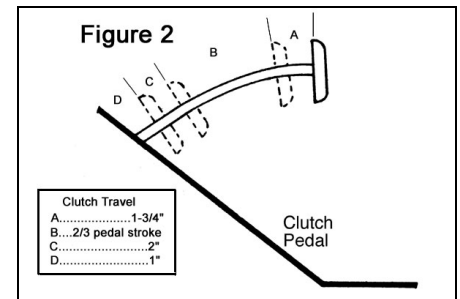

Zone (C) Complete Disengagement Zone. An area within the clutch linkage travel allowing the driver to change gears without encountering gear clash. This zone should be approximately 2 in length. (Figure 2)

Zone (D) the Clutch Brake. This area is for Pull Type clutch assemblies only. The clutch release bearing should contact the clutch brake when the clutch pedal is approximately 1 from the floor. (Figures 2 and 3)

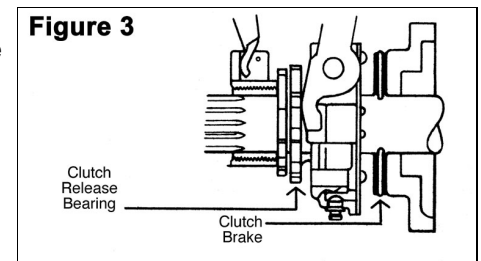

Always Remember:

1. That the clutch assembly job is to transmit engine torque without slipping and provide complete disengagement for gear changes (the rate of engagement or disengagement is a function of the linkage.)
2. In order to obtain complete clutch disengagement, the release bearing must move the release levers 1/2.

**ADJUSTMENT PROCEDURE
FOR 14" AND 15-1/2" ANGLE SPRING
2-PLATE CLUTCHES (MANUAL CLUTCHES)**

STEP 1: Establish Bearing Position

Set the distance between the bearing and the clutch brake between .500" and .562" (1/2" and 9/16"). (See Figure 1)

In order to move the bearing, you must rotate the adjusting ring inside the clutch cover. Light pressure applied to the clutch linkage will insure that the release bearing is stretched to provide the most accurate reading. (See Figure 2)

Important: The release bearing must move a minimum of .500" (1/2") to achieve "full clutch release".

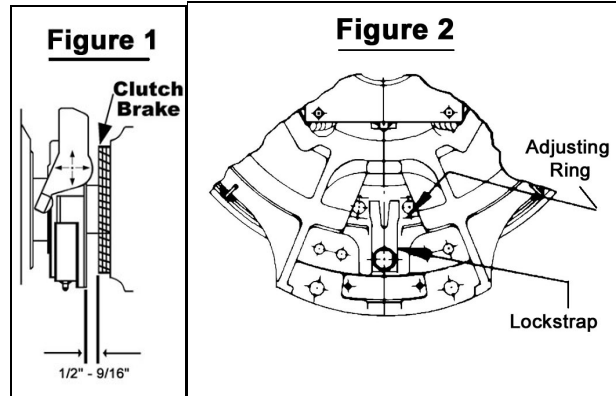

STEP 2: Adjust Clutch Brake

Proper adjustment of the brake is achieved by shortening or lengthening the external truck linkage rod.

1. Insert a .010 feeler gauge between the release bearing and clutch brake. Push the clutch pedal down to verify clutch brake squeeze.
2. The linkage should be adjusted to allow clamp up of the feeler gauge when the pedal is within .500 (1/2) from the floor and to release the feeler gauge when the pedal is 1 or less from the floor. (See Figure 3)

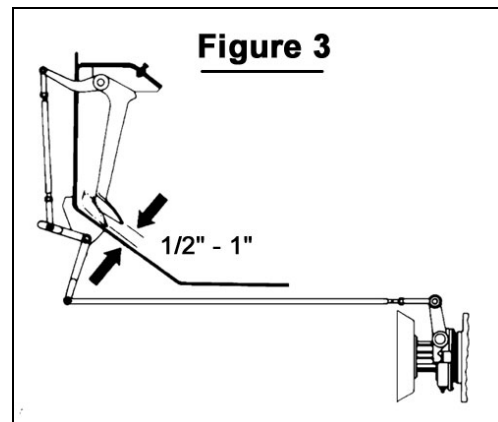

STEP 3: Check Free Pedal

The fingers on the release yoke should be approximately $.125$ ($1/8$) from the release bearing wear pads. (See Figure 4) This should equal about 1 – 3 of free pedal in the cab. (See Figure 5)

1. Routine clutch adjustment should occur when the free pedal is about half ($1/2$) of new installation free pedal. For example; if free pedal is set at 3 upon installation of the new clutch, clutch adjustment should occur at approximately 1.5 of free travel.

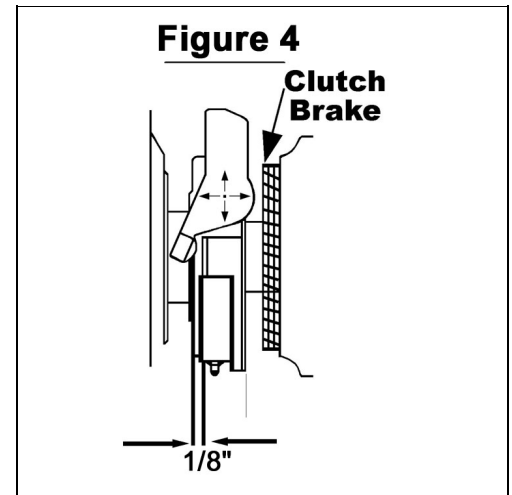

Important: If the bearing is the correct distance from the clutch brake and proper free pedal or clutch brake squeeze cannot be achieved, the truck does not have enough stroke to move the yoke the required distance. The pedal stroke in the cab must be increased by adjusting or modifying the upper pedal stop to raise the pedal and increase the pedal movement. (See Figure 5)

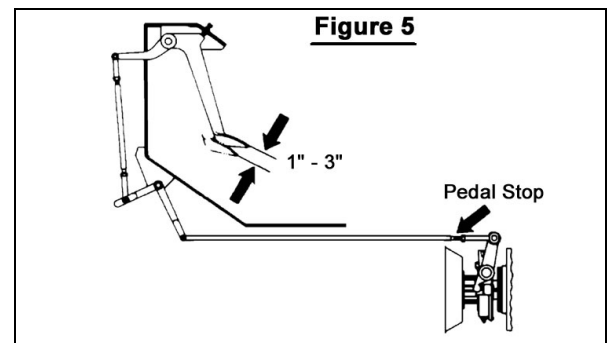

STEP 4: Reinstall the Lockstrap

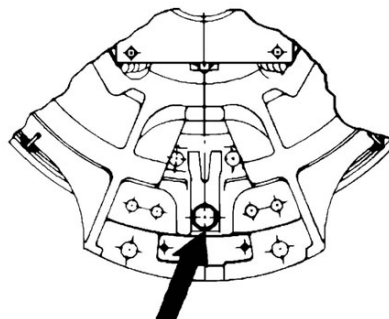

Reinstall the lockstrap

Driver Tips on How to Improve Clutch Performance

1. **Don't rest your foot on the clutch pedal while the vehicle is in motion.** This practice leads to: (a) premature release bearing failure because the bearing is constantly turning and (b) accelerated clutch disc friction facing wear due to clutch slippage.
2. **Don't allow the engine to lug.** A lugging engine creates damaging torsional vibrations that can destroy the driveline of a vehicle. Always keep your engine working within the recommended operating range (usually between 1500 to 1950 rpm).
3. **Don't overload the vehicle.** The vehicle's driveline, suspension, and brakes were designed for a specific capacity. When this capacity is exceeded, the life expectancy of these components will be decreased.
4. **Don't hold the vehicle on a hill by slipping the clutch.** The clutch was designed for short slip cycles and transmitting torque. Long periods of constant clutch slippage will create excessive heat and wear on the clutch disc friction facing causing premature failure.
5. **Don't coast with the clutch disengaged.** As a vehicle descends a grade it will increase in speed causing the disc assembly to rotate faster. If the disc is spun too fast, the friction facing will explode due to centrifugal force.
6. **Don't use any other gear except first (or low) to start the vehicle in motion.** Starting the vehicle in second gear requires approximately twice the slip cycle time that would be required for a first gear start, resulting in rapid facing wear and extreme heat.
7. **Don't allow irregular clutch action to go unreported.** Submit a drivers report after each trip and keep the maintenance director informed of possible problems. Your report could prevent a road service call or an expensive tow bill.
8. **Don't hold the clutch pedal to the floor while waiting for a traffic light to change or in a traffic jam.** Give the clutch release bearing a rest by putting the vehicle in neutral and letting the clutch pedal rise. This will allow the bearing to separate from the clutch release levers and stop turning (prolonging its life).
9. **Don't excessively slip the clutch when a vehicle is stuck.** Rocking the vehicle by quickly changing gears (reverse to first) or excessive clutch slippage, can cause extreme damage to the driveline. A tow charge would be less expensive than replacing the clutch, transmission, driveline, or a ring and pinion in the rear axle assembly.
10. **Don't allow an untrained driver to operate your vehicles.** Insist on a driver training program. It will save you and your fleet down time and maintenance costs.

Problem	Remedy
Chatter	
<ol style="list-style-type: none"> 1. Loose, broken or worn engine mounts. 2. Pedal linkage worn. 3. Loose or cracked clutch housing. 4. Spring shackles and mountings loose, worn or broken. 5. Misalignment. 6. Oil or grease on facings. 7. Warped or bent driven disc assembly. 8. Improper disc facing thickness. 9. Worn pilot bearing. 10. Wrong spring pressure in cover assembly. 11. Improper "A" dimension (type ML only). 12. Unequal quantity of shims under straps of MP clutch. 13. Release levers not parallel. 	<ol style="list-style-type: none"> 1. Tighten or replace. 2. Replace linkage. 3. Tighten or replace. 4. Tighten or replace. 5. Realign. 6. Install new facings or disc assembly. 7. Install driven disc assembly. 8. Install proper disc assembly. 9. Replace. 10. Replace with proper cover assembly. 11. Refer to "A" dimension chart for Type ML. Adjust to correct setting. 12. Use same quantity of shims under each strap. 13. Recheck installation.

Aggressive

- | | |
|--|--|
| <ol style="list-style-type: none"> 1. Release sleeve dry. 2. Worn or loose pedal linkage. 3. Excessive backlash in power train. 4. Warped driven disc. 5. Worn hub splines. 6. Worn splines on spline shaft. 7. Improper facing material. | <ol style="list-style-type: none"> 1. Lubricate release sleeve. 2. Replace or tighten. 3. Adjust or replace worn parts. 4. Install new disc assembly. 5. Install new disc assembly. 6. Replace shaft or install Lipe Spline-Saver disc kit. 7. Install proper driven disc assembly. |
|--|--|

Insufficient Release

- | | |
|--|---|
| <ol style="list-style-type: none"> 1. Broken or loose motor mounts. 2. Worn or loose pedal linkage. 3. Excessive idling speed. 4. Loose or worn facings. 5. Improper facing thickness. 6. Warped or bent driven disc assembly. 7. Lever settings wrong. 8. Worn splines. 9. Worn or rusty splines on splined shaft. 10. Worn pilot bearing | <ol style="list-style-type: none"> 1. Replace or tighten. 2. Replace or tighten. 3. Adjust to factory specs. 4. Replace facings or install new driven disc assembly. 5. Install proper driven disc assembly(s). 6. Install recommended driven disc assembly properly. 7. Refer to "A" dimension chart & re-check install. 8. Replace with new driven disc. assembly. 9. Repair, replace or install Lipe Spline-Saver disc kit. 10. Replace. |
|--|---|

Problem

Remedy

Hard Pedal

- | | |
|---|--|
| <ol style="list-style-type: none">1. Worn pedal linkage.2. Binding in pedal linkage.3. Excessive spring pressure in cover assembly.4. Contact pad of release bearing carrier worn by shifter yoke. | <ol style="list-style-type: none">1. Replace with new linkage.2. Lubricate and adjust.3. Install proper cover assembly.
4. Replace carrier and shifter yoke. Also check for proper hook-up to provide best linkage operating positions. |
|---|--|
-

Slippage

- | | |
|---|--|
| <ol style="list-style-type: none">1. Oil or grease on facings.2. Loose or worn facings.3. Flywheel burned, checked or cracked.4. Insufficient plate pressure.5. Improper "A" dimension (type ML only).6. Binding in pedal linkage7. Improper facing material. | <ol style="list-style-type: none">1. Replace facings or install new driven disc assembly. Correct oil leak.2. Replace facings or install new driven disc assembly.3. Replace or regrind.4. Install new cover assembly.5. Refer to "A" dimension chart for Type ML. Adjust to correct setting.6. Lubricate and adjust.7. Use correct facing or replace disc assembly. |
|---|--|
-

Vibration

- | | |
|---|--|
| <ol style="list-style-type: none">1. All or part of power train out of balance.2. One or more units in power train out of alignment.3. Worn spline shaft.4. Worn crankshaft bearings.5. Worn or loose engine mounts.6. Loose or out of balance universal joint.
7. Clutch out of balance.8. Worn disc splines. | <ol style="list-style-type: none">1. Check each unit individually and re-check as a complete assembly.2. Check and align (replace faulty component).3. Replace.4. Replace.5. Replace or tighten.6. Tighten or replace – check for balance.7. Install balanced unit.8. Replace disc. |
|---|--|

Adjusting Ring: Adjusts release bearing clearance. Clearance must be adjusted periodically to compensate for the wearing away of disc linings.

Angle Spring Clutch: A conventional clutch that uses a set of six coil springs set at an angle to the input shaft. The springs apply pressure to the pressure plate, engaging the clutch discs and forcing them to engage the flywheel.

Bell Housing (or Clutch Housing): The casing that houses the clutch that attaches to the transmission. (SAE #1, #2 & #3)

Center Plate: The plate that is connected by the flywheel or clutch cover (depending on clutch design) and separates the driven discs, increasing clutch capacity by providing additional friction area between the driven discs.

Ceramic Friction Material: A metallic based friction material found on driven discs. It is the most common friction material with the highest longevity.

Clamping Force: The amount of pressure exerted by the spring or springs to engage the clutch.

Clutch Brake: A device on the input shaft of non-synchronized transmissions that stops gears from rotating so that first and reverse gear may be engaged at a standstill.

Coaxial Coil Springs: Springs inside springs in the driven disc that increase capacity and help to neutralize engine torsion vibrations.

Dampened Discs: Discs that have vibration absorbing qualities that extend drivetrain component life.

Driven Discs: Contain the friction material and are splined to the transmissions input shaft, connecting the flywheel to the transmission.

Driveshaft: The shaft or shafts leading from the transmission that connect to the axle differential to supply power from the engine.

Flywheel: Connects the engine to the transmission via the clutch assembly. The driven discs of the clutch ride on the transmission input shaft and are clamped by the pressure plate to the flywheel, which is turned by the engine, powering the drive wheels.

Input Shaft: The splined shaft on the front of the transmission. It is attached to the transmission drive gear, and rests in the pilot bearing in the center of the flywheel. The splined shafts of the driven discs ride on the input shaft, causing it to rotate when they are clamped to the flywheel by the pressure plate.

Levers: Parts that multiply and transfer the force of the diaphragm spring from the retainer to the pressure plate in diaphragm-spring clutches.

Linkage: Components that link the clutch pedal to the clutch assembly, allowing the driver to engage or disengage the clutch.

Organic Friction Material: Non-asbestos substances that are used on clutch discs. They are softer and smoother than most ceramic facings, resulting in smoother, softer clutch engagement.

Pilot Bearing: Bearing in the center of the flywheel. The end of the input shaft rides here, allowing the shaft to stop rotating—despite the rotation of the flywheel—when the pressure plate is retracted and the Clutch Brake is applied.

Pressure Plate Assembly: Applies the force of the diaphragm or springs to the pressure plate, clamping the clutch discs between the pressure plate, center plate and flywheel. Also houses the adjusting ring and parts of the release bearing engagement.

Release Bearing Assembly: Transfers the movement of the clutch linkage to engage and disengage the clutch.

Straps: Connect the cover to the pressure plate, transmitting engine torque through the rotation of the flywheel and the clutch cover to the disc.

Rigid Discs: Have no vibration absorption qualities; usually contribute to increased wear on drivetrain components.

Torsion Vibration: Vibration at the flywheel created by the engine cylinder pressure pulses during fuel burning.

Notes

This page left blank intentionally.

Haldex develops and provides reliable and innovative solutions with focus on brake and air suspension products to the global commercial vehicle industry.

Listed on the Stockholm Stock Exchange, Haldex has annual sales of 3.7 billion SEK and employs 2,200 people.

Disclaimer: The products described within this literature, including without limitation, product features, specifications, designs, availability and pricing are subject to change by Haldex and its subsidiaries at any time without notice.

This document and other information from Haldex, its subsidiaries and authorized distributors provide product and/or system options for further investigation by users having technical expertise. It is important that you analyze all aspects of your application and review the information concerning the product or system, in the current literature or catalog. Due to the variety of operating conditions and applications for these products or systems, the user, through their own analysis and testing, is solely responsible for making the final selection of the products and systems and assuring that all performance, safety and warning requirements are met.

©2012, Haldex AB - This material may contain Haldex trademarks and third party trademarks, trade names, corporate logos, graphics and emblems which are the property of their respective companies. The contents of this document may not be copied, distributed, adapted or displayed for commercial purposes or otherwise without prior written consent from Haldex.

Austria

Haldex Wien Ges.m.b.H.
Vienna
Tel.: +43 1 8 69 27 97
Fax: +43 1 8 69 27 97 27
E-Mail: info.AT@haldex.com

Belgium

Haldex N.V.
Balegem
Tel.: +32 9 363 90 00
Fax: +32 9 363 90 09
E-Mail: info.BE@haldex.com

Brazil

Haldex do Brazil
São Paulo
Tel.: +55 12 3935 4000
E-Mail: info.BR@haldex.com

Canada

Haldex Ltd.
Cambridge, Ontario
Tel.: +1 519 621 6722
Fax: +1 519 621 3924
E-Mail: info.CA@haldex.com

China

Haldex International Trading Co. Ltd.
Shanghai
Tel.: +86 21 5240 0338
Fax: +86 21 5240 0177
E-Mail: info.CN@haldex.com

France

Haldex Europe SAS
Weyersheim (Strasbourg)
Tel.: +33 3 88 68 22 00
Fax: +33 3 88 68 22 09
E-Mail: info.EUR@haldex.com

Germany

Haldex Brake Products GmbH
Heidelberg
Tel.: +49 6 221 7030
Fax: +49 6 221 703400
E-Mail: info.DE@haldex.com

Hungary

Haldex Hungary Kft.
Szentlőrincváta
Tel.: +36 29 631 300
Fax: +36 29 631 301
E-Mail: info.HU@haldex.com

India

Haldex India Limited
Nasik
Tel.: +91 253 2380094
Fax: +91 253 2380729

Italy

Haldex Italia Srl.
Biassono (Milan)
Tel.: +39 039 47 17 02
Fax: +39 039 27 54 309
E-Mail: info.IT@haldex.com

Korea

Haldex Korea Ltd.
Seoul
Tel.: +82 2 2636 7545
Fax: +82 2 2636 7548
E-Mail: info.HKR@haldex.com

Mexico

Haldex de Mexico S.A. De C.V.
Monterrey
Tel.: +52 81 8156 9500
Fax: +52 81 8313 7090

Poland

Haldex Sp. z.o.o.
Praszka
Tel.: +48 34 350 11 00
Fax: +48 34 350 11 11
E-Mail: info.PL@haldex.com

Russia

OOO "Haldex RUS"
Moscow
Tel.: +7 495 747 59 56
Fax: +7 495 786 39 70
E-Mail: info.RU@haldex.com

Spain

Haldex España S.A.
Granollers
Tel.: +34 93 84 07 239
Fax: +34 93 84 91 218
E-Mail: info.ES@haldex.com

Sweden

Haldex Brake Products AB
Landskrona
Tel.: +46 418 47 60 00
Fax: +46 418 47 60 01
E-Mail: info.SE@haldex.com

United Kingdom

Haldex Ltd.
Newton Aycliffe
Tel.: +44 1325 310 110
Fax: +44 1325 311 834
E-Mail: info.GBAy@haldex.com

Haldex Brake Products Ltd.
Redditch
Tel.: +44 1527 499 499
Fax: +44 1527 499 500
E-Mail: info.GBRe@haldex.com

USA

Haldex Brake Products Corp.
Kansas City
Tel.: +1 816 891 2470
Fax: +1 816 891 9447
E-Mail: info.US@haldex.com



www.haldex.com

Innovative Vehicle Solutions